

Take a Few Moments to Do It Right

By James M. Lucas, P.E.

Today's steel joists and joist girders often have complex profiles and may be used as integral parts of moment frames to resist lateral loads. Unfortunately, the specification and detailing associated with the joist-to-column and girder-to-column connections is often poorly executed, severely undermining the design factor of safety.

Quite often, specifying engineers create frame action when it is neither required nor desired and then ignore its effects. Other times, they present the connections as resisting only lateral loads but fail to detail them to perform as such, causing stress reversals in components for which the manufacturer has not designed.

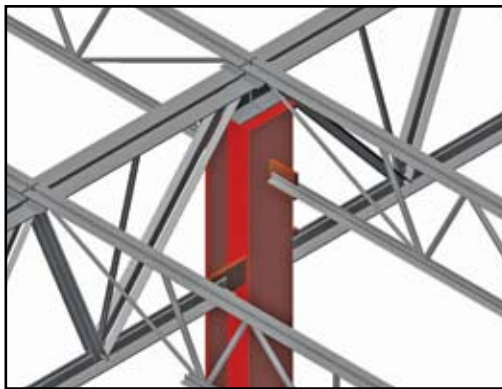

Figure 1: Typical Joist/Girder-to-Column Connection

Joist manufacturers have no statutory obligation (and usually no contractual obligation) to supply anything beyond what the Engineer of Record specifies. However, by virtue of their moral, ethical, and legal responsibility to make every reasonable effort to protect the life, health, safety and property of the public, any licensee employed by a manufacturer must question this condition.

Connection Types

The justification for neglecting continuity moments is based on the assumption that the connection depicted behaves as one of the following, as described by AISC:

- Type 2 Wind Connection per the *AISC Manual of Steel Construction, Allowable Stress Design, 9th Edition*, Part 5, Chapter A2.2.
- Type 3 Connection per the *AISC Manual of Steel Construction, Allowable Stress Design, 9th Edition*, Part 5, Chapter A2.2.
- Type PR (partially restrained) Connection per the *AISC Manual of Steel Construction, Load and Resistance Factor Design, 3rd Edition*, Part 16, Chapter A2 and *AISC Steel Construction Manual, 13th Edition*, Part 16, Chapter B3, Paragraph 6b(b).
- Flexible Moment Connection per the *AISC Manual of Steel Construction, Load and Resistance Factor Design, 3rd Edition*, Part 11 and *AISC Steel Construction Manual, 13th Edition*, Part 11.

Before discussing how these connections relate to steel joist construction, it is important to note that AISC limits the applicability of their specifications to structural steel. Section 2.1 of the *AISC Code of Standard Practice for Steel Buildings and Bridges* defines structural steel. Section 2.2 of this code specifically excludes open web joists, longspan joists, and joist girders from the structural steel classification. Whereas the joist industry employs AISC-like procedures in designing any hot-rolled sections used as joist components, the AISC reference is technically not applicable.

The inapplicability of the AISC specification notwithstanding, the joist industry recognizes Type 1 (fully restrained), Type 2 (simple shear), and Type 2 Wind connections, but *not* Type 3 (semi-rigid) connections. Although Type 2 Wind connections and Type 3 connections are similar, they are not designed to behave in the same manner.

In an effort to increase design awareness of Types 2 and 3 construction, the AISC LRFD Specification, 1st Edition combined them into a single category PR (partially restrained). The Type 2 Wind connection was reclassified as a Flexible Moment Connection (FMC) in the LRFD Specification, 3rd Edition and remains so in the 13th Edition.

Type 1 / Fully Restrained Connections

Type 1 connections transfer not only the lateral moments, i.e., wind and seismic, but also all continuity moments. The continuity moment specification is usually limited to live load

The Federal Case

OSHA requires that bottom chord stabilizer plates be located on all columns supporting joist products and that the bottom chord extensions of the supported members engage these plates, as represented in *Figure 1*. The purpose is to provide resistance to rolling over for the members at the columns before the erection stability bridging is installed.

A Moment of Neglect

Although not required by OSHA, contract drawings commonly note that the bottom chord extensions are to be welded to these plates. Frequently, this welding is to take place "after all dead load is in place" with the intent that the only continuity moment generated would be from live load. This concept is impractical if the dead load is intended to include all collateral loads — HVAC, sprinklers, lighting, ceilings, etc. After these systems are installed, access for welding is usually limited. Additionally, steel erectors prefer that their work advance in a substantially continuous sequence and don't want to return to the site after interior work is completed. Consequently, the continuity moments are likely to include a significant portion of the dead load.

When welding is specified, the drawings often show the connection represented in *Figure 1*. Sometimes the specifying engineer provides end moments from lateral and live loads but, all too often, omits all continuity values.

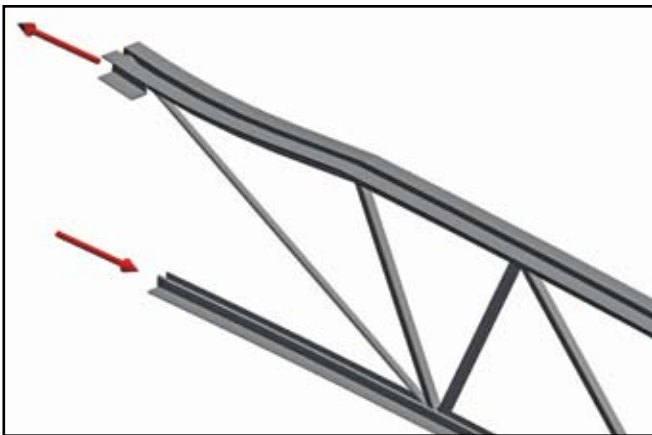

Figure 2: Joist Top Chord End Panel Under Eccentric Bending

but, in actuality, may also include collateral load and some dead load depending on the construction sequence, as discussed earlier. The specifying engineer needs to exercise due care when anticipating this sequence.

The joist and girder connection shown in *Figure 1* can be configured to perform as a Type 1 connection. If lateral moment is present, the top chord forces from the tie joists will induce a rollover on the girder seat, which must be stiffened to function as an extension of the column, as in Cases 1 and 2 below. Additionally, the end panels of the tie joist and joist girder top chords will need to be reinforced to resist the eccentric bending illustrated in *Figure 2*. The extent of this reinforcing is dependent upon the presence or absence of joist tie plates and girder strap angles.

1) Only Lateral Moment through the Seats

Joist tie plates and girder strap angles provide a direct load path between top chords for the forces associated with the continuity moments. When they are used, the only moment transferring through the seats is the portion carried by the column, i.e., the lateral moment and a small portion of the continuity moment. Since these moments are generally much less than the continuity moments, top chord end panel reinforcing will be far less extensive and less costly or not necessary at all. This configuration is depicted in *Figures 3* and *4*.

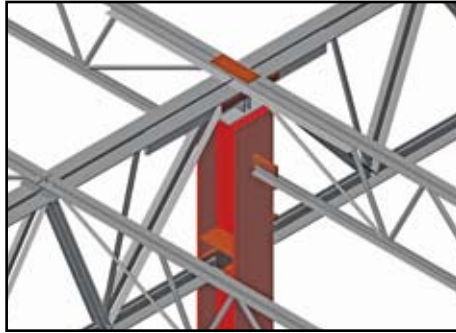

Figure 3: Common Type 1 Joist/Girder-to-Column Connection

2) All Moment through the Seats

Without tie plates and strap angles, the top chord force from all of the moments must travel down through the seat of one member, across the bearing surface, and up through the seat of the adjacent member. To compensate, the manufacturer must reinforce the end panels of the joist and girder top chords. In the case of the tie joists, the bearing surface is the top chord and seat assembly of the girder. Since the continuity forces at the top chord are in tension, they are pulling this assembly apart. This connection is similar to *Figure 4* minus the tie plates and strap angles.

This version of the Type 1 Connection requires the most meticulous shop fabrication and field installation measures to ensure proper performance. Reinforcing the top chord end panels and stiffening the girder seats require much greater attention to the manufacture of the members than the run of the mill products. If resisting lateral loads, the fastening of the girder seats to the column cap plate becomes critical, requiring a higher level of coordination among the Engineer of Record, the steel fabricator, and the joist manufacturer.

The design of the fastening, which the joist manufacturer normally excludes from their scope, is dependent on the girder seat proportions and stiffener arrangement. This directly impacts the design of the column cap plate and the welds that fasten it to the top of the column. It creates a chain of design responsibility that is far more complex than it needs to be. Furthermore, if manufacturing tolerances are not maintained at a more stringent level than the SJI norm, installation of this overly complicated assembly may require significant field modification.

3) No Moment through the Seats

A less complex alternative is to bear the joists and girders on seats welded to the sides of the columns, as depicted in *Figure 5*. This permits the use of moment plates to connect the member top chords

directly to the column, bypassing the need to transfer any chord forces through the seats, which eliminates the need for complex and costly top chord end panel reinforcement. This connection may be used without moment plates, but it tends to defeat the purpose; end panel reinforcing is still required.

In all cases, the column web is too flexible to transmit the bottom chord component of the lateral moment force couple into the column flanges for weak axis bending. Without web stiffeners, the force will merely pass through the column web resulting in tie joist continuity but no lateral frame action.

Type 2 Simple Shear Connections

Simple shear connections, treated as theoretical pins, transmit no moments. The simplest and most common configuration is that shown in *Figure 6*. It's cheap and easy. When lateral stability is provided via shear walls, braced frames, or any other means not requiring joist end fixity, this is the connection of choice.

Type 2 Wind / Flexible Moment Connections

Type 2 Wind connections are designed to transfer wind moments but not continuity moments. The AISC specification requires that "connections have adequate inelastic rotation capacity to avoid overstress of fasteners or welds under combined gravity and wind loading." The specification goes on to say, "Types 2 and 3 construction may necessitate some nonelastic, but self limiting, deformation of a structural steel part."

continued on next page

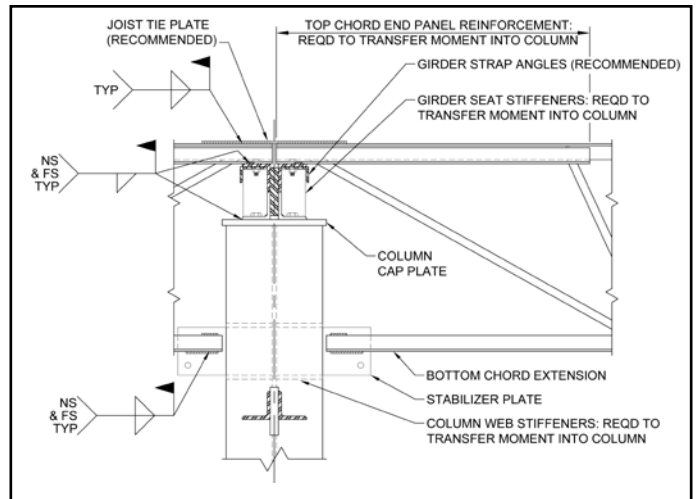

(4 a) Tie Joists in Elevation

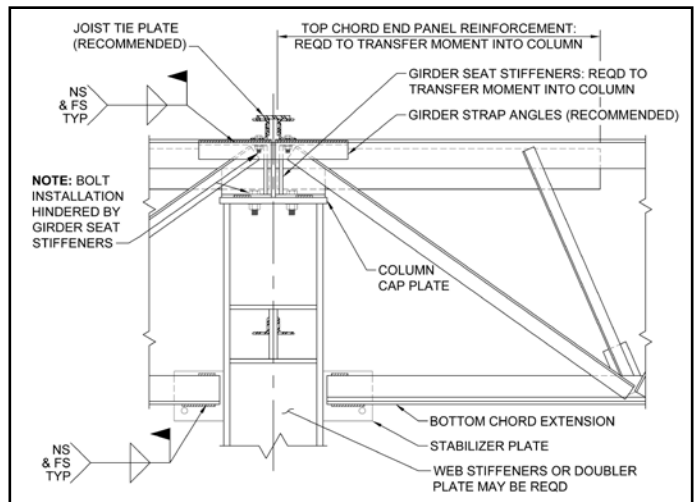

(4 b) Girders in Elevation

Figure 4: Type 1 Connection: Girder Bearing on Column Cap Plate

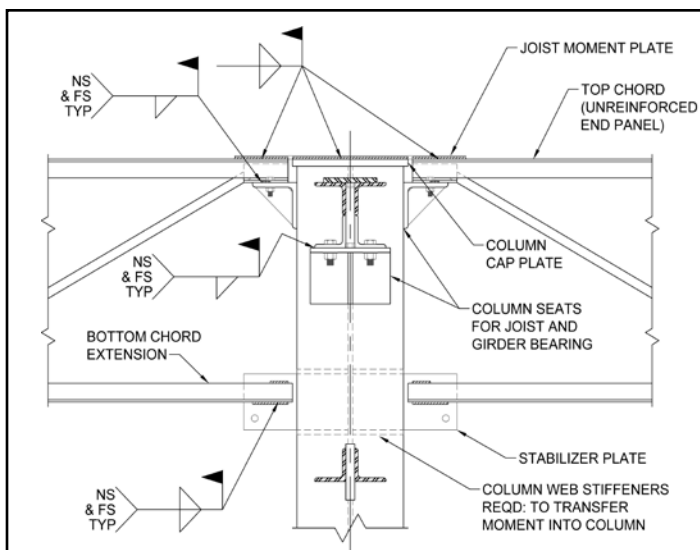

(5 a) Tie Joists in Elevation

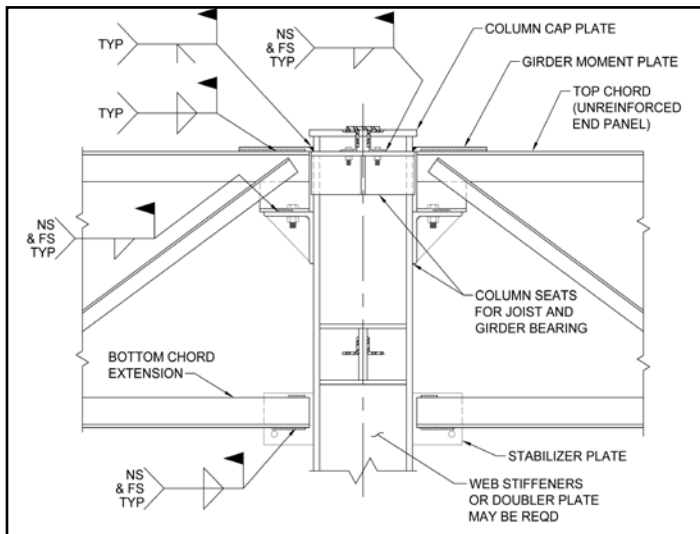

(5 b) Girders in Elevation

Figure 5: Type 1 Connection: Joists and Girders Bearing on Column Seats

The Nucor Vulcraft text, *Designing with Steel Joists, Joist Girders, Steel Deck* (Fisher, West, and Van de Pas), discusses the design procedure for a Type 2 Wind connection, which is analogous to AISC's flange-plated connection. Figure 7 illustrates Type 2 Wind connections for both tie joists and joist girders. Note that the members' top chords are connected directly to the column via moment plates that are proportioned to resist the wind moment and welded to the chord angles in a manner to allow the elongation necessary to provide inelastic rotation capacity.

Of the connections discussed in this article, the Type 2 Wind connection is the only configuration for which continuity moments can legitimately be neglected in the joist and girder design. As with Type 1 connections, the column must have web stiffeners.

Type 3 / Partially Restrained Connections

From an industry standpoint, there is currently no such thing as a semi-rigid joist or joist girder connection. The design of Type 3 connections requires for the associated members "a dependable and known moment capacity intermediate in degree between the rigidity of Type 1 and the flexibility of Type 2." The strength, stiffness and ductility characteristics of the connections must be incorporated in the analysis and design, and these characteristics "shall be documented in the technical literature or established by analytical or experimental means."

In the design procedure, the industry represents this intermediate rigidity in the form of moment rotation curves. These curves are based on empirical test data, which currently exists for wide flange sections only, and some of this data is deemed controversial. No such data exists for either steel joists or joist girders. The only entity having adequate information to analytically establish the necessary characteristics of these members is the joist manufacturer, and this is not within their typical scope of work.

When the axial loads from the end moment force-couples travel through the seats and into the top chords with eccentric bending (Figure 2), the condition has predictability of neither nonelastic deformation nor moment capacity under intermediate rotation. Therefore, reference to a Type 3 connection for joists or joist girders is inappropriate.

Arbitrary Neglect

When contract drawings show the connection represented in Figure 1, indicate bottom chord extensions to be welded to the stabilizer plates, and omit the continuity moment values based on an assumption of either Type 2 Wind or FMC behavior, they are at odds with both the structural steel and steel joist industries.

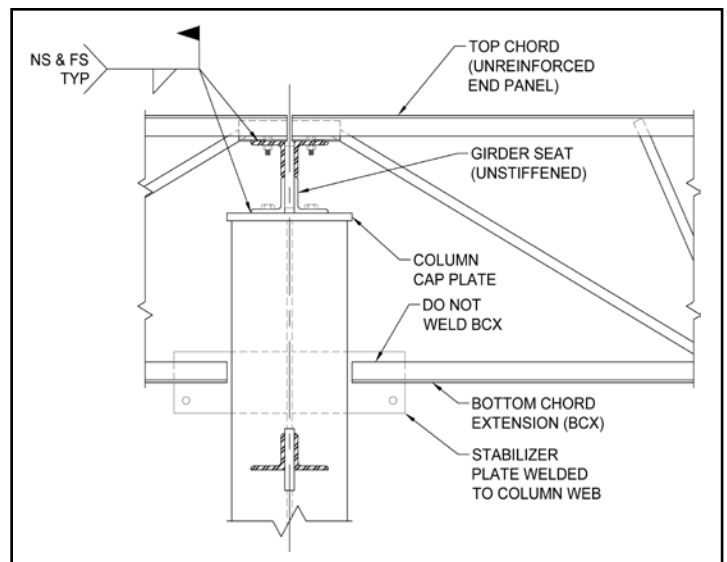

(6 a) Tie Joists in Elevation

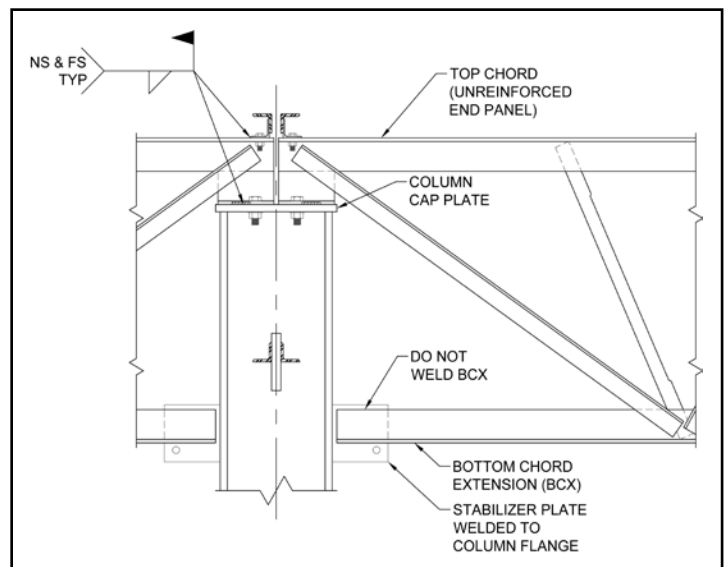

(6 a) Girders in Elevation

Figure 6: Type 2 Simple Shear Connection, Typical Configuration

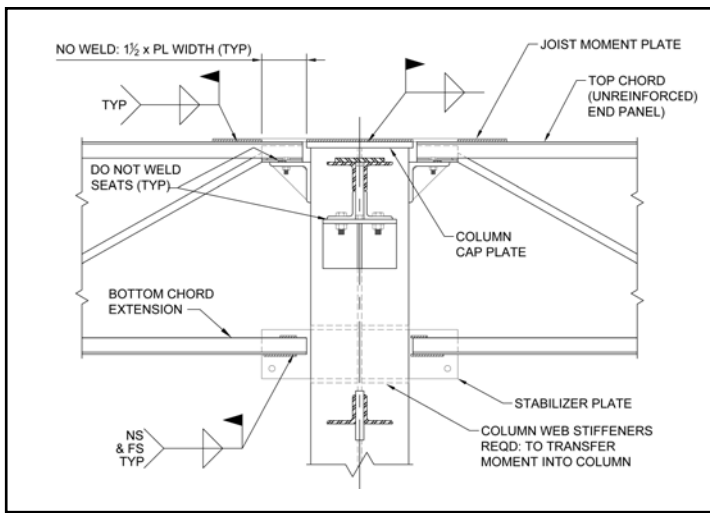

(7 a) Tie Joists in Elevation

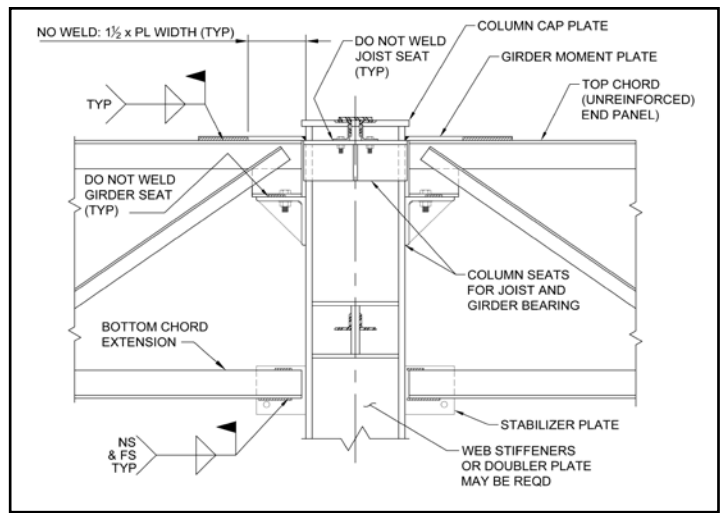

(7 b) Girders in Elevation

Figure 7: Type 2 Wind Connection

Dr. James M. Fisher addressed this issue in 1981 in an AISC *Engineering Journal* paper on the design of industrial buildings. He clearly states that the designer should not arbitrarily create continuity without specifying the proper loads. Although his comments were in regard to joist girders, this author's investigations indicate that the same assessment applies to tie joists, usually with more extreme overstresses.

In the AISC Steel Interchange, January 2005, Dr. Serge Zoruba of the Steel Solutions Center addressed a semi-rigid connection question, referring to the two flexible moment connections for which AISC has design criteria: flange-angle and flange-plated. The

answer concludes by stating, "We do not have design criteria for other types of FMC connections."

Nothing I've Designed Has Fallen Down, Yet.

A recent commercial project in Maryland is a textbook example of arbitrarily neglecting continuity moments. The contract documents indicated wind moments for all tie joists and joist girders, but no live load moment. During the approval process, the Engineer of Record insisted that the value was zero. They went on to claim that they had "done it this way for 25 years on thousands of buildings and never had a problem." Well, who can argue with that? The author has, repeatedly.

continued on next page

ADVERTISEMENT – For Advertiser Information, visit www.STRUCTUREmag.org

BRING ON THE TOUGH STUFF...

SUPPORTING INNOVATION

PLANTS:
 Point of Rocks, MD (301) 874-5141 Washington, MD (636) 239-6716 Jacksonville, FL (904) 781-0898 Sunnyside, WA 1-800-359-7308

Value Engineering
 - Challenging Connections
 - Compression Rings
 - Cost-Efficient Joist Substitutes

Fabrication Expertise
 - Decades of Experience
 - Technical Know-How
 - Constant Product Evolution

We Excel at:
 - Architecturally Unusual Designs
 - Schools
 - Churches
 - Distinct Commercial Designs

www.canam.ws/structure

To ascertain the magnitude of the problem, the live load end moment values (that the EOR refused to provide) were calculated. The resultant values were then applied to the joist and girder designs that were based on the contract document information. Analysis of the as-specified members using these values revealed component stress levels ranging from 120% to 130% of allowable. While the engineering community has tolerated low levels of overstress — less than 5% — on a limited basis, 20% or more is unacceptable by any standard.

The lack of a related failure during this time does not necessarily translate into 25 years of acceptable practice. We must not use such reasoning to blur the line between design assumptions justified by empirical testing in a controlled environment and those justified by “historical,” i.e., anecdotal, evidence.

Without empirical testing, the 1.67 factor of safety mandated by the Steel Joist Institute cannot be verified. Therefore, the “we’ve been doing it this way for 25 years” justification is in violation of the building code regardless of anecdotal evidence. In reality, it represents 25 years of benefiting from: the minimum joist design factor of safety, the absence of full design load conditions, unforeseeable stress redistributions, et al, all resulting in a bogus sense of security.

So, What Have We Learned from All This?

Except in the case of a correctly detailed Type 2 Wind connection, when bottom chord extensions are to be welded to stabilizer plates — with or without specified lateral end moments — the industry currently recognizes only Type 1 FR (fully restrained) behavior.

The industry publications are clear: *neglecting continuity is not consistent with industry standards*. The arbitrary omission of continuity moments undermines the design factor of safety required by code, the purpose of which is to help offset the potential for variability in materials, loads, and construction quality. The design consultant should never consciously elect to erode the safety factor before the project even leaves the office.

If the Engineer of Record specifies that the bottom chords are to be welded to the stabilizer plates, then the proper end moments must be provided. If Type 2 Wind is intended, then the connection must be detailed as such.

The fall of the Twin Towers brought intense scrutiny to steel joist construction. In this environment, the structural engineer needs to be vigilant in exercising good engineering practice and sound judgment based on analytical and/or empirical data. ■

Jim Lucas was formerly Engineering Manager for Canam Steel Corporation in Point of Rocks, MD. He is now a Senior Project Engineer with CenterPoint Engineering, Inc. in Mechanicsburg, PA. Jim can be reached via email at James.Lucas.PE@gmail.com.

References

1. *AISC Manual of Steel Construction, Allowable Stress Design, 9th Edition*, Part 5, Chapter A2.1.
2. *AISC Manual of Steel Construction, Load and Resistance Factor Design, 3rd Edition*, Part 16, Chapter A1.
3. *AISC Manual of Steel Construction, Allowable Stress Design, 9th Edition*, Part 5, Chapter A2.2.
4. *AISC Manual of Steel Construction, Allowable Stress Design, 9th Edition*, Part 5, Chapter A2.2(3).
5. *AISC Manual of Steel Construction, Load and Resistance Factor Design, 3rd Edition*, Part 16, Chapter A2.
6. *AISC Steel Construction Manual, 13th Edition*, Part 16, Chapter B3, Paragraph 6b(b)
7. Fisher, J. “Structural Details in Industrial Buildings,” *Engineering Journal*, American Institute of Steel Construction, 1981, Third Quarter, pp 83-89.