

# STANDARD SPECIFICATION

## FOR CJ-SERIES COMPOSITE STEEL JOISTS

CJ-Series Adopted by the Steel Joist Institute May 10, 2006  
Revised to May 18, 2010, Effective December 31, 2010  
Revised to November 9, 2015; Effective August 1, 2016

### SECTION 1.

## SCOPE AND DEFINITIONS

#### 1.1 SCOPE

The *Standard Specification for CJ-Series Composite Steel Joists*, hereafter referred to as the Specification, covers the design, manufacture, application, and erection stability and handling of **CJ-Series Composite Steel Joists** in buildings or other structures, where other structures are defined as those structures designed, manufactured, and erected in a manner similar to buildings. **CJ-Series joists** shall be designed using Load and Resistance Factor Design (LRFD) in accordance with this Specification.

#### 1.2 OTHER REGULATIONS

**CJ-Series joists** shall be erected in accordance with the Occupational Safety and Health Administration (OSHA), 29 CFR Part 1926, Safety Standards for Steel Erection, Subpart R – Steel Erection. The erection of **CJ-Series joists** shall be in accordance with the requirements of Section 1926.757, Open Web Steel Joists.

#### 1.3 APPLICATION

This Specification includes Section 1 through Section 8. The user notes shall not be part of the Specification.

**User Note:** User notes are intended to provide practical guidance in the use and application of this Specification.

#### 1.4 DEFINITIONS

The following terms shall, for the purposes of this Specification, have the meanings shown in this Section. Where terms are not defined in this Section, those terms shall have their ordinary accepted meanings in the context in which it applies.

**CJ-Series** shall be open web, parallel chord, load-carrying steel members utilizing hot-rolled or cold-formed steel, including cold-formed steel whose yield strength has been attained by cold working. Shear connection between the top chord and overlying concrete slab allows the steel joist and slab to act together as an integral unit after the concrete has adequately cured.

The **CJ-Series joist** standard designation is determined by its nominal depth in inches (mm), the letters “**CJ**”, followed by the total uniform composite load, uniform composite live load, and finally the uniform composite dead load. Composite Steel Joists shall be designed in accordance with this Specification to support the loads defined by the specifying professional.

**User Note:** **CJ-Series joists** are suitable for the direct support of one-way floors and roof slabs or decks. **CJ-Series joists** have parallel chords and are standardized in depths from 10 inches (254 mm) through 96 inches (2438 mm), for spans through 120 feet (36.58 m).

Two standard types of **CJ-Series** joists are designed and manufactured. These types are underslung (top chord bearing) or square-ended (bottom chord bearing).

The **CJ-Series** joists have bearing depths that range from 2½ inches (64 mm) to 7½ inches (191 mm).

## 1.5 STRUCTURAL DESIGN DRAWINGS AND SPECIFICATIONS

The structural design drawings and specifications shall meet the requirements in the *Code of Standard Practice for Composite Steel Joists*, except for deviations specifically identified in the design drawings and/or specifications.

## SECTION 2. **REFERENCED SPECIFICATIONS, CODES AND STANDARDS**

### 2.1 REFERENCES

The standards listed below shall be considered part of the requirements of this Specification. Where conflicts occur between this Specification and a referenced standard, the provisions of this Specification shall take precedence unless otherwise so stated. This section lists the standards that are referenced in this Specification. The standards are listed in alphabetical order by name of the standards developer organization, with the specific standard designation, title and date of each referenced standard below.

ACI International (ACI), Farmington Hills, MI

ACI 318-14, *Building Code Requirements for Structural Concrete and Commentary*

ACI 318M-14, *Metric Building Code Requirements for Structural Concrete and Commentary*

American Institute of Steel Construction, Inc. (AISC), Chicago, IL

ANSI/AISC 360-10 *Specification for Structural Steel Buildings*

American Iron and Steel Institute (AISI), Washington, DC

ANSI/AISI S100-2012 *North American Specification for the Design of Cold-Formed Steel Structural Members*

American Society of Civil Engineers (ASCE), Reston, VA

SEI/ASCE 7-10 *Minimum Design Loads for Buildings and Other Structures*

American National Standard SJI 200 - 2015

American Society of Testing and Materials, ASTM International (ASTM), West Conshohocken, PA

ASTM A6/A6M-14, *Standard Specification for General Requirements for Rolled Structural Steel Bars, Plates, Shapes, and Sheet Piling*

ASTM A36/A36M-14, *Standard Specification for Carbon Structural Steel*

ASTM A242/242M-13, *Standard Specification for High-Strength Low-Alloy Structural Steel*

ASTM A307-14, *Standard Specification for Carbon Steel Bolts and Studs, 60 000 PSI Tensile Strength*

ASTM A325-14 *Standard Specification for Structural Bolts, Steel, Heat Treated, 120/105 ksi Minimum Tensile Strength*

ASTM A325M-14 *Standard Specification for Structural Bolts, Steel, Heat Treated 830 MPa Minimum Tensile Strength (Metric)*

ASTM A370-14, *Standard Test Methods and Definitions for Mechanical Testing of Steel Products*

ASTM A500/A500M-13, *Standard Specification for Cold-Formed Welded and Seamless Carbon Steel Structural Tubing in Rounds and Shapes*

ASTM A501/A501M-14 *Standard Specification for Hot-Formed Welded and Seamless Carbon Steel Structural Tubing*

ASTM A529/A529M-14, *Standard Specification for High-Strength Carbon-Manganese Steel of Structural Quality*

ASTM A572/A572M-15, *Standard Specification for High-Strength Low-Alloy Columbium-Vanadium Structural Steel*

ASTM A588/A588M-15, *Standard Specification for High-Strength Low-Alloy Structural Steel, up to 50 ksi [345 MPa] Minimum Yield Point, with Atmospheric Corrosion Resistance*

ASTM A606/A606M-09a, *Standard Specification for Steel, Sheet and Strip, High-Strength, Low-Alloy, Hot-Rolled and Cold-Rolled, with Improved Atmospheric Corrosion Resistance*

ASTM A992/A992M-11 (2015), *Standard Specification for Structural Steel Shapes*

ASTM A1008/A1008M-15, *Standard Specification for Steel, Sheet, Cold-Rolled, Carbon, Structural, High-Strength Low-Alloy and High-Strength Low-Alloy with Improved Formability, Solution Hardened, and Bake Hardenable*

ASTM A1011/A1011M-14, *Standard Specification for Steel, Sheet and Strip, Hot-Rolled, Carbon, Structural, High-Strength Low-Alloy, High-Strength Low-Alloy with Improved Formability, and Ultra-High Strength*

ASTM A1065/A1065M-15 *Standard Specification for Cold-Formed Electric-Fusion (ARC) Welded High-Strength Low Alloy Structural Tubing in Shapes with 50 ksi (345 MPA) Minimum Yield Point*

ASTM A1085-13 *Standard Specification for Cold-Formed Welded Carbon Steel Hollow Structural Sections (HSS)*

American Welding Society (AWS), Miami, FL

AWS A5.1/A5.1M-2012, *Specification for Carbon Steel Electrodes for Shielded Metal Arc Welding*

AWS A5.5/A5.5M:2006, *Specification for Low-Alloy Steel Electrodes for Shielded Metal Arc Welding*

AWS A5.17/A5.17M-97:R2007, *Specification for Carbon Steel Electrodes and Fluxes for Submerged Arc Welding*

AWS A5.18/A5.18M:2005, *Specification for Carbon Steel Electrodes and Rods for Gas Shielded Arc Welding*

AWS A5.20/A5.20M:2005, *Specification for Carbon Steel Electrodes for Flux Cored Arc Welding*

AWS A5.23/A5.23M:2011, *Specification for Low-Alloy Steel Electrodes and Fluxes for Submerged Arc Welding*

AWS A5.28/A5.28M:2005, *Specification for Low-Alloy Steel Electrodes and Rods for Gas Shielded Arc Welding*

AWS A5.29/A5.29M:2010, *Specification for Low Alloy Steel Electrodes for Flux Cored Arc Welding*

AWS D1.1/D1.1M:2015, *Structural Welding Code - Steel*

AWS D1.3/D1.3M:2008, *Structural Welding Code Sheet Steel*

Steel Deck Institute (SDI), Glenshaw, PA

ANSI/SDI C-2011, Standard for Composite Steel Floor Deck - Slabs

ANSI/SDI NC-2010, Standard for Non-Composite Steel Floor Deck

Steel Joist Institute (SJI), Florence, SC

ANSI/SJI 100-2015, *Standard Specification for K-Series, LH-Series, and DLH-Series Open Web Steel Joists and for Joist Girders*

**User Note:** The following references provide additional practical guidance in the use and application of this Specification:

Code of Federal Regulations (CFR), Occupational Safety and Health Administration (OSHA), 29 CFR Part 1926, Safety Standards for Steel Erection; Subpart R – Steel Erection; January 18, 2001, Washington, D.C

Steel Joist Institute (SJI), Florence, SC

ANSI/SJI-CJ COSP-2015, *Code of Standard Practice for Composite Steel Joists*

Technical Digest No. 3 (2007), *Structural Design of Steel Joist Roofs to Resist Ponding Loads*

Technical Digest No. 5 (2014), *Vibration of Steel Joist-Concrete Slab Floors*

Technical Digest No. 6 (2010), *Structural Design of Steel Joist Roofs to Resist Uplift Loads*

Technical Digest No. 8 (2008), *Welding of Open Web Steel Joists and Joist Girders*

Technical Digest No. 9 (2008), *Handling and Erection of Steel Joists and Joist Girders*

Technical Digest No. 10 (2003), *Design of Fire Resistive Assemblies with Steel Joists*

Technical Digest No. 11 (2007), *Design of Lateral Load Resisting Frames Using Steel Joists and Joist Girders*

Technical Digest No. 13 (2016), *Design of Composite Steel Joists*

The Society for Protective Coatings (SSPC), Pittsburgh, PA

SSPC 08-02 Steel Structures Painting Manual – Volume 2 – Systems and Specifications, 2011 Edition

SSPC Paint 15 Steel Joist Shop Primer/Metal Building Primer (Includes 2004 Revisions) 05/01/1999

Alsamsam, Iyad (1988), *An Experimental Investigation Into the Behavior of Composite Open Web Steel Joists*, Master's Thesis, Department of Civil and Mineral Engineering Institute of Technology, University of Minnesota, MN.

ASCE Task Committee on Design Criteria for Composite Structures in Steel and Concrete (1996), *Proposed Specification and Commentary for Composite Joists and Composite Trusses*, *ASCE Journal of Structural Engineering*, Vol. 122, No. 4, April.

Atkinson, A.H., and Cran, J.A. (1972), *The Design and Economics of Composite Open-Web Steel Joists*, Canadian Structural Engineering Conference.

Avci, Onur and Easterling, Sam (2003), *Strength of Welded Weak Position Shear Studs*, Report No. CE/VPI-ST03/08, Department of Civil and Environmental Engineering, Virginia Polytechnic Institute and State University, Blacksburg, VA.

Azmi, M.H. (1972), *Composite Open-Web Trusses with Metal Cellular Floor*, A Master of Engineering Thesis, McMaster University, Hamilton, Ontario, April.

Band, B.S. and Murray, T.M. (1999), *Floor Vibrations: Ultra-Long Span Joist Floors*, *Proceedings of the 1999 Structures Congress*, American Society of Civil Engineers, New Orleans, Louisiana, April 18-21.

Boice, Michael and Murray, T.M. (2002), *Report of Floor Vibration Testing, University of Tennessee Medical Center, Knoxville, TN*, Report CE/VPI-ST02/10, Department of Civil and Environmental Engineering, Virginia Polytechnic Institute and State University, Blacksburg, VA.

Brattland, A., and Kennedy, D.J. Laurie (1992), *Flexural Tests of Two Full-Scale Composite Trusses*, Canadian Journal of Civil Engineering, Volume 19, Number 2, April, pp. 279-295.

CISC (1984), Chien, E.Y.L., and Ritchie, J.K., *Design and Construction of Composite Floor Systems*, Chapter 5 – “Composite Open Web Steel Joists and Trusses”, Canadian Institute of Steel Construction, Willowdale, Ontario.

CISC ICCA (2012), *Handbook of Steel Construction*, includes S16-09 “Design of Steel Structures”, Section 16 - “Open-web steel joists”, Tenth Edition, Canadian Institute of Steel Construction, Willowdale, Ontario.

Corrin, Michael (1993), Stanley D. Lindsey & Associates, Ltd, *312 Elm Street- Innovation Pays Off*, The Military Engineer, No. 554, January - February.

Cran, J.A. (1972), *Design and Testing Composite Open Web Steel Joists*, Technical Bulletin 11, Stelco, January.

Curry, Jamison Hyde (1988), *Full Scale Tests on Two Long-Span Composite Open-Web Steel Joists*, Master’s Thesis, Department of Civil and Mineral Engineering Institute of Technology, University of Minnesota, MN.

Easterling, W.S., Gibbings, D.R. and Murray, T.M. (1993) *Strength of Shear Studs in Steel Deck on Composite Beams and Joists*, AISC Engineering Journal, Second Quarter, pp 44-55.

Easterling, W. Samuel (1999) *Composite Joist Behavior and Design Requirements*, ASCE Structures Congress, New Orleans, LA, April 18-21.

Easterling, W. Samuel, Samuelson, David and Murray, Thomas M. (2000), *Behavior and Design of Longspan Composite Joists*, Fourth ASCE Composite Construction in Steel and Concrete Conference, Banff, Alberta, Canada, May 28-June 2.

Federal Register, Department of Labor, Occupational Safety and Health Administration (2001), 29 CFR Part 1926 Safety Standards for Steel Erection; Final Rule, §1926.757 Open Web Steel Joists - January 18, 2001, Washington, D.C.

Gibbings, D. R. and Easterling, W.S. (1991), *Strength of Composite Long Span Joists*, Report CE/VPI-ST91/02, Department of Civil and Environmental Engineering, Virginia Polytechnic Institute and State University, Blacksburg, VA.

Gibbings, D. R. and Easterling, W.S. (1991), *Strength of Composite Long Span Joists- Addendum*, Report CE/VPI-ST91/02 (Addendum), Department of Civil and Environmental Engineering, Virginia Polytechnic Institute and State University, Blacksburg, VA.

Lembeck, Jr., H.G. (1965), *Composite Design of Open Web Steel Joists*, M.Sc. Thesis, Washington University, St. Louis, MO.

Leon, R.T. and Curry, J., (1987), *Behavior of Long Span Composite Joists*, ASCE Structures Congress Proceedings., Florida, August, pp. 390-403.

Lyons, John; Easterling, Sam; and Murray, Tom (1994), *Strength of Welded Shear Studs, Vols. I and II*, Report No. CE/VPI-ST94/07, Department of Civil and Environmental Engineering, Virginia Polytechnic Institute and State University, Blacksburg, VA

Nguyen, S.; Gibbings, D. R.; Easterling, W.S.; and Murray, T. M. (1992), *Elastic –Plastic Finite Element Modeling of Long Span Composite Joists with Incomplete Interaction*, Department of Civil and Environmental Engineering, Virginia Polytechnic Institute and State University, Blacksburg, VA.

Nguyen, S.; Gibbings, D. R.; Easterling, W.S.; and Murray, T. M. (1992), *Further Studies of Composite Long-Span Joists*, Report No. CE/VPI-ST92/05, Department of Civil and Environmental Engineering, Virginia Polytechnic Institute and State University, Blacksburg, VA.

Patras, Wayne and Azizinimini, Atrod (1991), *Open Web Composite Joist Systems Utilizing Ultra-High Strength Concrete*, Masters Thesis, College of Engineering and Technology, University of Nebraska – Lincoln, NE.

Robinson, H. and Fahmy, E.H. (1978), *The Design of Partially Connected Composite Open-Web Joists*, Canadian Journal of Civil Engineering, Volume 5, pp. 611-614.

Roddenberry, Michelle; Easterling, Sam; and Murray, Tom (2000), *Strength Prediction Method for Shear Studs and Resistance Factor for Composite Beams, Volume No. II*, Department of Civil and Environmental Engineering, Virginia Polytechnic Institute and State University, Blacksburg, VA.

Roddenberry, Michelle; Easterling, Sam; and Murray, Tom (2002), *Behavior and Strength of Welded Stud Shear Connectors*, CE/VPI-ST02/04, Department of Civil and Environmental Engineering, Virginia Polytechnic Institute and State University, Blacksburg, VA.

Roddenberry, Michelle; Easterling, Sam; and Murray, Tom (2002), *Behavior and Strength of Welded Stud Shear Connectors-Data Report*, CE/VPI-ST02/05, Department of Civil and Environmental Engineering, Virginia Polytechnic Institute and State University, Blacksburg, VA.

Samuelson, David (1999) *Composite Joist Case Histories*, ASCE Structures Congress, New Orleans, LA, April 18-21.

Samuelson, David (2003) *Composite Joist Advantage*, Modern Steel Construction Magazine, September.

Samuelson, David (2002) *Composite Steel Joists*, AISC Engineering Journal, Vol. 39, No. 3, Third Quarter.

Samuelson, David (2004) SJI Updates – *Expanded Load Tables for Noncomposite Joists/Joist Girders and Development of New Composite Joist Series*, North American Steel Construction Conference, Long Beach, CA, March 24-27.

Sublett, Charles and Easterling, Sam (1992), *Strength of Welded Headed Studs in Ribbed Metal Deck on Composite Joists*, CE/VPI-ST92/03, Department of Civil and Environmental Engineering, Virginia Polytechnic Institute and State University, Blacksburg, VA.

Tide, R.H.R. and Galambos, T.V. (1970), *Composite Open-Web Steel Joists*, AISC Engineering Journal, January, Vol. 7, No. 1.

Van Malssen, S.H. (1984), *The Effects of Arc Strikes on Steel Used in Nuclear Construction*, Welding Journal, American Welding Society, Miami, FL, July 1984.

Viest, Ivan; Colaco, Joseph; Furlong, Richard; Griffis, Lawrence; Leon, Roberto; and Wyllie Jr., Loring A. (1997), *Section 3.8 – Composite Joists and Trusses, Composite Construction Design for Buildings*, Co-published by American Society of Civil Engineers, and McGraw Hill.

## SECTION 3. MATERIALS

### 3.1 STEEL CHORD AND WEB MEMBERS

The steel used in the manufacture of **CJ**-Series joists shall conform to one of the following ASTM specifications:

Carbon Structural Steel, ASTM A36/A36M

High-Strength Low-Alloy Structural Steel, ASTM A242/A242M

Cold-Formed Welded and Seamless Carbon Steel Structural Tubing in Rounds and Shapes, ASTM A500/A500M

High-Strength Carbon-Manganese Steel of Structural Quality, ASTM A529/A529M

High-Strength Low-Alloy Columbium-Vanadium Structural Steel, ASTM A572/A572M

High-Strength Low-Alloy Structural Steel up to 50 ksi [345 MPa] Minimum Yield Point with Atmospheric Corrosion Resistance, ASTM A588/A588M

Steel, Sheet and Strip, High-Strength, Low-Alloy, Hot-Rolled and Cold-Rolled, with Improved Atmospheric Corrosion Resistance, ASTM A606/A606M

Structural Steel Shapes, ASTM A992/A992M

Steel, Sheet, Cold-Rolled, Carbon, Structural, High-Strength Low-Alloy, High-Strength Low-Alloy with Improved Formability, Solution Hardened, and Bake Hardenable, ASTM A1008/A1008M

Steel, Sheet and Strip, Hot-Rolled, Carbon, Structural, High-Strength Low-Alloy, High-Strength Low-Alloy with Improved Formability, and Ultra High Strength, ASTM A1011/A1011M

EXCEPTION: Steel used in the manufacture of **CJ-Series** joists shall be permitted to be of suitable quality ordered or produced to other than the listed ASTM specifications, provided that such material in the state used for final assembly and manufacture is weldable and is proven by tests performed by the producer or manufacturer to have properties, in accordance with Section 3.2.

### 3.2 MECHANICAL PROPERTIES

**3.2.1 Minimum Yield Strength:** Steel used for **CJ-Series** joists shall have a minimum yield strength determined in accordance with one of the procedures specified in this section, which is equal to the yield strength assumed in the design.

**User Note:** The term "Yield Strength" as used herein designates the yield level of a material as determined by the applicable method outlined in paragraph 13.1 "Yield Point", and in paragraph 13.2 "Yield Strength", of ASTM A370, *Standard Test Methods and Definitions for Mechanical Testing of Steel Products*, or as specified in Section 3.2.3.

Evidence that the steel furnished meets or exceeds the design yield strength shall, if requested, be provided in the form of an affidavit or by witnessed or certified test reports.

For material used without consideration of increase in yield strength resulting from cold forming, the specimens shall be taken from as-rolled material. In the case of such material, the mechanical properties of which conform to the requirements of one of the listed ASTM specifications in Section 3.1, the test specimens and procedures shall conform to those of the applicable ASTM specification and to ASTM A370.

**3.2.2 Other Materials:** For materials where the mechanical properties do not conform to the requirements of one of the ASTM specifications listed in Section 3.1, these materials shall conform to the following requirements:

- a) The specimens shall comply with ASTM A370.
- b) The specimens shall exhibit a yield strength equal to or exceeding the design yield strength.
- c) The specimens shall have an elongation of not less than 20 percent in 2 inches (51 mm) for sheet strip, or 18 percent in 8 inches (203 mm) for plates, shapes and bars with adjustments for thickness for plates, shapes and bars as prescribed in either ASTM A36/A36M, A242/A242M, A500/A500M, A529/A529M, A572/A572M, A588/A588M, or A992/A992M, whichever ASTM specification is applicable, on the basis of design yield strength.
- d) The number of tests for (a), (b), and (c) above shall be as prescribed in ASTM A6/A6M for plates, shapes, and bars; and ASTM A606/A606M, A1008/A1008M and A1011/A1011M for sheet and strip.

**3.2.3 As-Formed Strength:** If as-formed strength is utilized for cold-formed steel members, the test reports shall show the results performed on full section specimens in accordance with the provisions of AISI S100. The test reports shall also indicate compliance with the following additional requirements:

- a) The yield strength calculated from the test data shall equal or exceed the design yield strength.
- b) Where tension tests are made for acceptance and control purposes, the tensile strength shall be at least 8 percent greater than the yield strength of the section.
- c) Where compression tests are used for acceptance and control purposes, the specimen shall withstand a gross shortening of 2 percent of its original length without cracking. The length of the specimen shall be not greater than 20 times the least radius of gyration.
- d) If any test specimen fails to pass the requirements of subparagraphs (a), (b), or (c) above, as applicable, two retests shall be made of specimens from the same lot. Failure of one of the retest specimens to meet such requirements shall be the cause for rejection of the lot represented by the specimens.

### 3.3 WELDING ELECTRODES

**3.3.1 Welding Electrodes:** The welding electrodes used for arc welding shall be in accordance with the following:

- a) For connected members both having a specified minimum yield strength greater than 36 ksi (250 MPa), one of the following electrodes shall be used:

AWS A5.1: E70XX  
 AWS A5.5: E70XX-X  
 AWS A5.17: F7XX–EXXX, F7XX–ECXXX flux electrode combination  
 AWS A5.18: ER70S-X, E70C-XC, E70C-XM  
 AWS A5.20: E7XT-X, E7XT-XM  
 AWS A5.23: F7XX–EXXX-XX, F7XX–ECXXX-XX  
 AWS A5.28: ER70S-XXX, E70C-XXX  
 AWS A5.29: E7XTX-X, E7XTX-XM

- b) For connected members both having a specified minimum yield strength of 36 ksi (250 MPa) or one having a specified minimum yield strength of 36 ksi (250 MPa), and the other having a specified minimum yield strength greater than 36 ksi (250 MPa), one of the following electrodes shall be used:

AWS A5.1: E60XX  
 AWS A5.17: F6XX-EXXX, F6XX-ECXXX flux electrode combination  
 AWS A5.20: E6XT-X, E6XT-XM  
 AWS A5.29: E6XTX-X, E6XTX-XM

or any of those listed in Section 3.3.1(a).

**3.3.2 Other Welding Methods:** Other welding methods, providing equivalent strength as demonstrated by tests, shall be permitted to be used.

### 3.4 PAINT

**CJ-Series joists** shall be provided unpainted to facilitate installation of welded shear studs, unless otherwise specified.

When specified, the standard shop paint shall be considered an impermanent and provisional coating and shall conform to one of the following:

- a) The Society for Protective Coatings, SSPC Paint Specification No. 15.  
 b) Or, shall be a shop paint which meets the minimum performance requirements of SSPC Paint Specification No. 15.

**User Note:** The standard shop paint is intended to protect the steel for only a short period of exposure in ordinary atmospheric conditions. It is usually considered preferable to leave **CJ-Series joists** unpainted due to concerns that paint may potentially hinder the installation of welded shear studs to the joist top chord.

## SECTION 4. DESIGN AND MANUFACTURE

### 4.1 METHOD

**CJ-Series joist design** shall be based on achieving the nominal flexural strength of the composite member and is designed as a one-way, composite joist system that meets the following criteria:



- a) Members are simply-supported and are not considered part of a designated lateral force resisting system, such as a braced frame or moment frame.
- b) Horizontal shear connection is achieved using welded steel stud anchors, except as provided in Section 8..

**CJ-Series** joists shall be designed in accordance with this Specification as simply-supported trusses supporting a floor or roof deck so constructed as to brace the top chord of the steel joists against lateral buckling. Where any applicable design feature is not specifically covered herein, the design shall be in accordance with the following specifications:

- a) Where the steel used consists of hot-rolled shapes, bars or plates, AISC 360.
- b) For members which are cold-formed from sheet or strip steel, AISI S100.

**4.1.1 Design Basis:** **CJ-Series** joist designs shall be in accordance with the provisions in this Specification using Load and Resistance Factor Design (LRFD) as specified by the specifying professional for the project.

**4.1.2 Loads, Forces and Load Combinations:** The loads and forces used for the **CJ-Series** joist design shall be calculated by the specifying professional in accordance with the applicable building code and specified and provided on the structural drawings.

For nominal concentrated loads, which have been accounted for in the specified uniform loads, the addition of chord bending moments or an added shop or field web member due to these nominal concentrated loads shall not be required provided that the sum of the concentrated loads within a chord panel does not exceed 100 pounds and the attachments are concentric to the chord. When exact dimensional locations for concentrated loads which do not meet the above criteria are provided by the specifying professional, the **CJ-Series** joist shall be designed for the loads and load locations provided without the need for additional field applied web members at the specified locations.

The load combinations shall be specified by the specifying professional on the structural drawings in accordance with the applicable building code. In the absence of an applicable building code, the load combinations shall be those stipulated in SEI/ASCE 7 Section 2.3 for Load and Resistance Factor Design.

At a minimum, the required stress for LRFD designs shall be computed for the factored loads based on the factors and load combinations as follows:

- a) Non-composite
 

$1.4D_c$	(4.1-1)
$1.2D_c + 1.6L_c$	(4.1-2)

Where:

- $D_c$  = construction dead load due to weight of the joist, the metal decking, and the fresh concrete, lb/ft<sup>2</sup> (kPa)
- $L_c$  = construction live load due to the work crews and the construction equipment, lb/ft<sup>2</sup> (kPa)

- b) Composite
 

$1.4D$	(4.1-3)
$1.2D + 1.6(L, \text{ or } L_r, \text{ or } S, \text{ or } R)$	(4.1-4)

Where:

- $D$  = dead load due to the weight of the structural elements and the permanent features of the structure, lb/ft<sup>2</sup> (kPa)
- $L$  = live load due to occupancy and movable equipment, lb/ft<sup>2</sup> (kPa)
- $L_r$  = roof live load, lb/ft<sup>2</sup> (kPa)
- $S$  = snow load, lb/ft<sup>2</sup> (kPa)
- $R$  = load due to initial rainwater or ice exclusive of the ponding contribution, , lb/ft<sup>2</sup> (kPa)

## 4.2 DESIGN STRESSES

**4.2.1 Design Using Load and Resistance Factor Design (LRFD):** CJ-Series joists shall have their components so proportioned that the required stresses,  $f_u$ , shall not exceed  $\phi F_n$  where,

- $f_u$  = required stress, ksi (MPa)
- $F_n$  = nominal stress, ksi (MPa)
- $\phi$  = resistance factor
- $\phi F_n$  = design stress, ksi (MPa)
- $F_y$  = specified minimum yield stress, ksi (MPa)
- $E$  = modulus of elasticity of steel, ksi (MPa)

**4.2.2 Stresses:** The calculation of design stress for chords shall be based on a yield strength,  $F_y$ , of the material used in manufacturing equal to 50 ksi (345 MPa). The calculation of design stress for all other joist elements shall be based on a yield strength,  $F_y$ , of the material used in manufacturing, but shall not be less than 36 ksi (250 MPa) nor greater than 50 ksi (345 MPa). Yield strengths greater than 50 ksi shall not be used for the design of any members.

**4.2.2.1 Tension:**  $\phi_t = 0.90$  (LRFD)

$$\text{Design Stress} = 0.9F_y \quad (4.2-1)$$

**4.2.2.2 Compression:**  $\phi_c = 0.90$  (LRFD)

$$\text{Design Stress} = 0.9F_{cr} \quad (4.2-2)$$

Where:

For members with  $k\ell/r \leq 4.71\sqrt{E/QF_y}$

$$F_{cr} = Q \left[ 0.658^{\left(\frac{QF_y}{F_e}\right)} \right] F_y \quad (4.2-3)$$

For members with  $k\ell/r > 4.71\sqrt{E/QF_y}$

$$F_{cr} = 0.877F_e \quad (4.2-4)$$

Where  $F_e$  = Elastic buckling stress determined in accordance with Equation 4.2-5

$$F_e = \frac{\pi^2 E}{\left(\frac{k\ell}{r}\right)^2} \quad (4.2-5)$$

In the above equations,  $\ell$  is the length,  $k$  is the effective length factor, and  $r$  is the corresponding radius of gyration of the member as defined in Section 4.3.  $E$  is equal to 29,000 ksi (200,000 MPa).

**User Note:**  $\ell$  should be taken as the distance in inches (mm) between panel points for the chord members and web members.

For hot-rolled sections and cold-formed angles, the form factor,  $Q$ , shall be taken as the full reduction factor for slender compression members as determined in accordance with AISC 360-10.

Where a compression web member, either a hot-rolled section or a cold-formed angle, is a crimped-end angle member intersecting at the first bottom chord panel point, then Q shall be determined as follows:

$$Q = [5.25/(w/t)] + t \leq 1.0 \quad (4.2-6a)$$

Where:

w = angle leg length, inches  
t = angle leg thickness, inches

or,

$$Q = [5.25/(w/t)] + (t/25.4) \leq 1.0 \quad (4.2-6b)$$

Where:

w = angle leg length, mm  
t = angle leg thickness, mm

For all other cold-formed sections the method of calculating the nominal compression strength shall be in accordance with AISI S100.

#### 4.2.2.3 Bending: $\phi_b = 0.90$ (LRFD)

Bending calculations shall be based on the elastic section modulus.

For chords and web members other than solid rounds:  $F_n = F_y$

$$\text{Design Stress} = \phi_b F_n = 0.9F_y \quad (4.2-7)$$

For web members of solid round cross section:  $F_n = 1.6 F_y$

$$\text{Design Stress} = \phi_b F_n = 1.45F_y \quad (4.2-8)$$

For bearing plates used in joist seats:  $F_n = 1.5 F_y$

$$\text{Design Stress} = \phi_b F_n = 1.35F_y \quad (4.2-9)$$

#### 4.2.2.4 Weld Strength: $\phi_w = 0.75$ (LRFD)

Shear at throat of fillet welds, flare bevel groove welds, partial joint penetration groove welds, and plug/slot welds shall be determined as follows:

$$\text{Nominal Shear Stress} = F_{nw} = 0.6F_{exx} \quad (4.2-10)$$

$$\text{Design Shear Strength} = \phi R_n = \phi_w F_{nw} A = 0.45F_{exx} A_w \text{ (LRFD)} \quad (4.2-11)$$

Where:

$F_{exx}$  is determined as follows:

E70 series electrodes or F7XX-EXXX flux-electrode combinations	$F_{exx} = 70$ ksi (483 MPa)
E60 series electrodes or F6XX-EXXX flux-electrode combinations	$F_{exx} = 60$ ksi (414 MPa)

$A_w$  = effective throat area, where:

For fillet welds,  $A_w$  = effective throat area

Other design methods demonstrated to provide sufficient strength by testing shall be permitted to be used.

For flare bevel groove welds, the effective weld area is based on a weld throat width, T (in.) and web

diameter, D (in.), where:

$$T = 0.12D + 0.11 \text{ (in.)} \quad (4.2-12a)$$

or,

For flare bevel groove welds, the effective weld area is based on a weld throat width, T (mm) and web diameter, D (mm), where:

$$T = 0.12D + 2.8 \text{ (mm)} \quad (4.2-12b)$$

For plug/slot welds,  $A_w$  = cross-sectional area of the hole or slot in the plane of the faying surface provided that the hole or slot meets the requirements of AISC 360.

**User Note:** For more on plugs/slot welds see Steel Joist Institute Technical Digest No. 8, "Welding of Open-Web Steel Joists and Joist Girders".

Strength of resistance welds and complete-joint-penetration groove or butt welds in tension or compression (only where the stress is normal to the weld axis) shall be equal to the base metal strength:

$$\phi_t = \phi_c = 0.90 \text{ (LRFD)}$$

$$\text{Design Stress} = 0.9 F_y \quad (4.2-13)$$

### 4.3 MAXIMUM SLENDERNESS RATIOS

The slenderness ratios,  $1.0\ell/r$  and  $1.0\ell_s/r$  of members as a whole or any component part shall not exceed the values given in Table 4.3-1, Part A.

**4.3.1 Effective Slenderness Ratios:** The effective slenderness ratio,  $k\ell/r$  to be used in calculating the nominal stresses,  $F_{cr}$  and  $F'_e$ , is the largest value as determined from Table 4.3-1, Part B and Part C, and modified where required with Equation 4.3-1.

**4.3.2 Compression Members:** In compression members where fillers or ties are used, they shall be spaced so that the  $\ell_s/r_z$  ratio of each component does not exceed the governing  $\ell/r$  ratio of the member as a whole. The terms used in Table 4.3-1 shall be defined as follows:

- $\ell$  = length center-to-center of panel points, except  $\ell = 36$  inches (914 mm) for calculating  $\ell/r_y$  of the top chord member for **CJ-Series** joists, in. (mm)
- $\ell_s$  = maximum length center-to-center between panel point and filler (tie), or between adjacent fillers (ties), in. (mm)
- $r_x$  = member radius of gyration about the horizontal axis of the **CJ-Series** joist, in. (mm)
- $r_y$  = member radius of gyration about the vertical axis of the **CJ-Series** joist, in. (mm)
- $r_z$  = least radius of gyration of a member component, in. (mm)

Compression web members shall be those web members subject to compressive axial loads under gravity loading.

**4.3.3 Tension Members:** Tension web members shall be those web members subject to tension axial loads under gravity loading, and which shall be permitted to be subject to compressive axial loads under alternate loading conditions.

**User Note:** An example of a non-gravity alternate loading condition is net uplift.

**4.3.4 Top Chords:** For top chords, the end panel(s) shall be the panels between the bearing seat and the first primary interior panel point comprised of at least two intersecting web members.

**4.3.5 Built-Up Web Members:** For built-up web members composed of two interconnected shapes, where  $\ell_s/r_z > 40$ , a modified slenderness ratio  $\left(\frac{k\ell}{r_y}\right)_m$  shall replace  $\frac{k\ell}{r_y}$  in Equations 4.2-3, 4.2-4, and 4.2-5, where:

$$\left(\frac{k\ell}{r_y}\right)_m = \sqrt{\left(\frac{k\ell}{r_y}\right)^2 + \left(\frac{k_i\ell_s}{r_z}\right)^2} \quad (4.3-1)$$

Where:

- $k_i$  = 0.50 for angles back-to-back
- = 0.75 for channels back-to-back

**TABLE 4.3-1**

<b>MAXIMUM AND EFFECTIVE SLENDERNESS RATIOS</b>						
Description		$k\ell/r_x$	$k\ell/r_y$	$k\ell/r_z$	$k\ell_s/r_z$	
<b>I. TOP CHORD INTERIOR PANELS</b>						
<b>A.</b>		The slenderness ratios, $1.0\ell/r$ and $1.0\ell_s/r$ , of members as a whole or any component part shall not exceed 90.				
<b>B.</b>		The effective slenderness ratio for CJ-Series joists, $k\ell/r$ , to determine $F_{cr}$ where k is:				
1.	Two shapes with fillers or ties	0.75	0.94	---	1.0	
2.	Two shapes without fillers or ties	---	---	0.75	---	
3.	Single component members	0.75	0.94	---	---	
<b>C.</b>		For bending, the effective slenderness ratio, $k\ell/r$ , to determine $F'_e$ where k is:				
		0.75	---	---	---	
<b>II. TOP CHORD END PANELS</b>						
<b>A.</b>		The slenderness ratios, $1.0\ell/r$ and $1.0\ell_s/r$ , of members as a whole or any component part shall not exceed 120.				
<b>B.</b>		The effective slenderness ratio for CJ-Series joists, $k\ell/r$ , to determine $F_{cr}$ where k is:				
1.	Two shapes with fillers or ties	1.0	0.94	---	1.0	
2.	Two shapes without fillers or ties	---	---	1.0	---	
3.	Single component members	1.0	0.94	---	---	
<b>C.</b>		For bending, the effective slenderness ratio, $k\ell/r$ , to determine $F'_e$ where k is:				
		1.0	---	---	---	
<b>III. ALL BOTTOM CHORD PANELS</b>						
<b>A.</b>		The slenderness ratios, $1.0\ell/r$ and $1.0\ell_s/r$ , of members as a whole or any component part shall not exceed 240.				
<b>B.</b>		For members subject to compression, the effective slenderness ratio for CJ-Series joists, $k\ell/r$ , to determine $F_{cr}$ where k is:				
1.	Two shapes with fillers or ties	0.9	0.94	---	1.0	
2.	Two shapes without fillers or ties	---	---	0.9	---	
3.	Single component members	0.9	0.94	---	---	
<b>C.</b>		For bending, the effective slenderness ratio, $k\ell/r$ , to determine $F'_e$ where k is:				
		0.9	---	---	---	
<b>IV. WEB MEMBERS</b>						
<b>A.</b>		The slenderness ratios, $1.0\ell/r$ and $1.0\ell_s/r$ , of members as a whole or any component part shall not exceed 240 for a tension member or 200 for a compression member.				
<b>B.</b>		For members subject to compression, the effective slenderness ratio for CJ-Series joists, $k\ell/r$ , to determine $F_{cr}$ where k is:				
1.	Two shapes with fillers or ties	0.75	1.0	---	1.0	
2.	Two shapes without fillers or ties	---	---	1.0	---	
3.	Single component members	0.75	0.9*	---	---	
*For end tension web members subject to compression, k shall equal 0.80						

## 4.4 MEMBERS

### 4.4.1 Chord Members

#### 4.4.1.1 Non-composite Design

The bottom chord shall be designed as an axially loaded tension member.

The top chord shall resist the construction loads, at which time the joist behaves non-compositely. An analysis shall be made using an effective depth of the joist to determine the member forces due to construction loads. The effective depth for a non-composite joist shall be considered the vertical distance between the centroids of the top and bottom chord members.

The minimum horizontal flat leg width and minimum thickness of the top chord shall be as specified in Table 4.4-1.

**TABLE 4.4-1  
MINIMUM TOP CHORD SIZES FOR INSTALLING WELDED SHEAR STUDS**

Shear Stud Diameter, in. (mm)	Minimum Horizontal Flat Leg Width, in. (mm)	Minimum Leg Thickness, in. (mm)
0.375 (10)	1.50 (38)	0.125 (3.2)
0.500 (13)	1.75 (44)	0.167 (4.2)
0.625 (16)	2.00 (51)	0.209 (5.3)
0.750 (19)	2.50 (64)	0.250 (6.3)

The top chord shall be designed as a continuous member subject to combined axial and bending stresses. It shall be so proportioned that for LRFD:

At the panel point:

$$f_{au} + f_{bu} \leq 0.9F_y \quad (4.4-1)$$

At the mid panel:

$$\text{for, } \frac{f_{au}}{\phi_c F_{cr}} \geq 0.2, \quad \frac{f_{au}}{\phi_c F_{cr}} + \frac{8}{9} \left[ \frac{C_m f_{bu}}{\left[ 1 - \left( \frac{f_{au}}{\phi_c F_e} \right) \right] Q \phi_b F_y} \right] \leq 1.0 \quad (4.4-2)$$

$$\text{for, } \frac{f_{au}}{\phi_c F_{cr}} < 0.2, \quad \frac{f_{au}}{2\phi_c F_{cr}} + \left[ \frac{C_m f_{bu}}{\left[ 1 - \left( \frac{f_{au}}{\phi_c F_e} \right) \right] Q \phi_b F_y} \right] \leq 1.0 \quad (4.4-3)$$

Where:

$f_{au}$  =  $P_u/A$  = required compressive stress using LRFD load combinations, ksi (MPa)

$P_u$  = required axial strength using LRFD load combinations, kips (N)

$A$  = area of the top chord, in.<sup>2</sup> (mm<sup>2</sup>)

$f_{bu}$  =  $M_u/S$  = required bending stress at the location under consideration using LRFD load combinations, ksi (MPa)

- $M_u$  = required flexural strength using LRFD load combinations, kip-in. (N-mm)  
 $S$  = elastic section modulus, in.<sup>3</sup> (mm<sup>3</sup>)  
 $F_{cr}$  = nominal axial compressive stress in ksi (MPa) based on  $k\ell/r$  as defined in Section 4.3  
 $C_m$  =  $1 - 0.3 f_{au}/\phi_c F'_e$  for end panels  
 $C_m$  =  $1 - 0.4 f_{au}/\phi_c F'_e$  for interior panels  
 $Q$  = form factor defined in Section 4.2.2.2  
 $\phi_c$  = resistance factor for compression = 0.90  
 $\phi_b$  = resistance factor for flexure = 0.90  
 $F_y$  = specified minimum yield strength, ksi (MPa)  
 $F'_e$  =  $\frac{\pi^2 E}{(k\ell/r_x)^2}$ , ksi (MPa),

where  $\ell$  is the length,  $k$  is the effective length factor, and  $r_x$  is the corresponding radius of gyration of the member as defined in Section 4.3

- $E$  = modulus of elasticity, 29,000 ksi (200,000 MPa)

The joist top chord shall be considered as laterally braced by the floor slab or roof deck provided the requirements of Section 5.9.5 are met.

The top chord and bottom chord shall be designed such that at each joint complies with Equation 4.4-4:

$$f_{vmod} \leq \phi_v F_n \quad (\text{LRFD, } \phi_v = 1.00) \quad (4.4-4)$$

Where:

- $F_n$  = nominal shear stress =  $0.6F_y$ , ksi (MPa)  
 $f_t$  = axial stress =  $P/A$ , ksi (MPa)  
 $f_v$  = shear stress =  $V/bt$ , ksi (MPa)  
 $f_{vmod}$  = modified shear stress =  $(\frac{1}{2})\sqrt{f_t^2 + 4f_v^2}$   
 $b$  = length of vertical part(s) of cross section, in. (mm)  
 $t$  = thickness of vertical part(s) of cross section, in. (mm)

It shall not be necessary to design the top chord and bottom chord for the modified shear stress,  $f_{vmod}$ , where a round bar web member is continuous through a joint. The minimum required shear of Section 4.4.2 (25 percent of the maximum end reaction) shall not be required when evaluating Equation 4.4-4.

#### 4.4.1.2 Composite Design

The distance between the centroid of the tension bottom chord and the centroid of the concrete compression block,  $d_e$ , shall be computed using a concrete stress of  $0.85f'_c$  and an effective concrete width,  $b_e$ , taken as the sum of the effective widths for each side of the joist centerline, each of which shall be the least value of the following:

- a) one-eighth of the joist span, center-to-center of supports;
- b) one-half the distance to the center-line of the adjacent joist;
- c) the distance to the edge of the slab.

$$a = A_b F_y / (0.85 f'_c b_e) \leq t_c, \text{ in. (mm)} \quad (4.4-5)$$

$$d_e = d_j - y_{bc} + h_{deck} + t_c - a/2, \text{ in. (mm)} \quad (4.4-6)$$



Where:

- a = depth of concrete compressive stress block, in. (mm)
- A<sub>b</sub> = cross-sectional area of **CJ**-Series steel joist bottom chord, in.<sup>2</sup> (mm<sup>2</sup>)
- b<sub>e</sub> = effective width of concrete slab over the joist, in. (mm)
- d<sub>j</sub> = **CJ**-Series steel joist depth, in. (mm)
- f'<sub>c</sub> = specified compressive strength of concrete, ksi (MPa)
- F<sub>y</sub> = specified minimum yield stress of **CJ**-Series joist bottom chord, ksi (MPa)
- h<sub>deck</sub> = height of metal deck, in. (mm)
- t<sub>c</sub> = thickness of concrete slab above the metal deck, in. (mm)
- y<sub>bc</sub> = vertical distance to centroidal axis of bottom chord measured from the bottom of the bottom chord, in. (mm)

When the metal deck ribs are perpendicular to the **CJ**-Series joists, the concrete below the top of the metal deck shall be neglected when determining section properties and in calculating the concrete compressive stress block.

The first top chord end panel member shall be designed for the full factored load requirements as a non-composite member per Section 4.4.1.1.

$$M_u \leq \phi M_n \quad (4.4-7)$$

Where:

- $\phi M_n$  = minimum design flexural strength of composite section as determined from Equations 4.4-8, 4.4-9, 4.4-10, and 4.4-11, kip-in. (N-mm)
- M<sub>u</sub> = required flexural strength determined from applied factored loads, kip-in. (N-mm)

The design flexural strength of the composite section,  $\phi M_n$ , shall be computed as the least value of the following limit states:

a) Bottom Chord Tensile Yielding:  $\phi_t = 0.90$        $\phi M_n = \phi_t A_b F_y d_e$       (4.4-8)

b) Bottom Chord Tensile Rupture:  $\phi_{tr} = 0.75$        $\phi M_n = \phi_{tr} A_n F_u d_e$       (4.4-9)

c) Concrete Crushing:  $\phi_{cc} = 0.85$        $\phi M_n = \phi_{cc} 0.85 f'_c b_e t_c d_e$       (4.4-10)

d) Shear Connector Strength:  $\phi_{stud} = 0.90$        $\phi M_n = \phi_{stud} N Q_n d_e$       (4.4-11)

Where:

- A<sub>b</sub> = cross-sectional area of **CJ**-Series joist bottom chord, in.<sup>2</sup> (mm<sup>2</sup>)
- A<sub>n</sub> = net cross-sectional area of the **CJ**-Series joist bottom chord, in.<sup>2</sup> (mm<sup>2</sup>)
- b<sub>e</sub> = effective width of concrete slab over the **CJ**-Series joist, in. (mm)
- d<sub>e</sub> = vertical distance from the centroid of **CJ**-Series joist bottom chord to the centroid of resistance of the concrete in compression, in. (mm)
- F<sub>u</sub> = tensile strength of the **CJ**-Series joist bottom chord, ksi (MPa)
- F<sub>y</sub> = specified minimum yield stress of **CJ**-Series joist bottom chord, ksi (MPa)
- N = number of shear studs between the point of maximum moment and zero moment
- Q<sub>n</sub> = shear capacity of a single shear stud, kips (kN)
- t<sub>c</sub> = minimum thickness of the concrete slab above the top of the metal deck, in. (mm)

Where composite flexural strength is governed by the strength of shear connection as provided by Equation 4.4-11, the strength of shear connection, NQ<sub>n</sub>, shall be no less than 50 percent of the bottom chord yield strength.

#### 4.4.2 Web Members

The vertical shears to be used in the design of the web members shall be determined by including all loads, i.e. from the controlling load combination from Section 4.1.2, but such vertical shears shall be not less than the following:

- a) 25 percent of the maximum end reaction from the design load combinations;
- b) Tension web members controlled by (a) shall be designed for a compressive force resulting from a factored shear value of:

$$V_{cmin} = \frac{(1.6w_L)L}{8} \tag{4.4-12}$$

Where:

- $w_L$  = non-factored live load due to occupancy and moveable equipment, plf (kN/m)
- $L$  = design length for the **CJ-Series** joist as defined in Table 5.2-1, where design length = Span – 0.33 ft. (Span (m) – 0.102 m)
- $V_{cmin}$  = minimum factored compressive design shear in tension web members, lbs (kN)

**4.4.2.1 Redundant Web Member:** Interior vertical web members used in modified Warren type web systems shall be designed to resist the gravity loads supported by the member plus 2.0 percent of the composite bottom chord axial force.

Redundant web members in end panels shall be designed to resist the gravity loads supported by the member plus an additional load of ½ of 1.0 percent of the top chord axial force.

**4.4.2.2 Single Component Web Member:** In those cases where a single component web member is attached to the outside of the stem of a tee or double angle chord or any other orientation of a single web member which creates an out-of-plane moment, the web member design shall account for the stresses due to eccentricity.

##### 4.4.2.2.1 Uncrimped Single Angle Web Member

For 1 inch (25 mm) uncrimped single angle web members where one leg is placed flat against one chord member in the gap, the resulting eccentricities and the effects in loading shall be considered in the design. A minimum of 50 percent of the required weld shall be deposited to each chord angle.

For angles subjected to tension loading, combined axial and bending stresses shall be proportioned in accordance with Equation 4.4-1.

For angles subjected to compression loading, the following requirements shall be met:

- at the panel point, combined axial and bending stresses shall be proportioned in accordance with Equation 4.4-1.
- at the mid length, the strength shall meet Equations 4.4-2 or 4.4-3, and 4.4-13:

$$\frac{f_{au}}{\phi_c F_{crz}} \leq 1.0 \tag{4.4-13}$$

Where:

- $f_{au}$  =  $P_u/A$  = required tensile or compressive stress, ksi (MPa)
- $P_u$  = required axial strength using LRFD load combinations, kips (N)
- $A$  = area of the uncrimped angle web, in.<sup>2</sup>, (mm<sup>2</sup>)
- $f_{bu}$  =  $M_u/S$  = required bending stress, ksi (MPa)

$M_u$  = required flexural strength =  $0.5P_u \left( \frac{\text{chord gap}}{2} - \bar{y} \right)$ , kip-in. (N-mm)

$S$  = elastic section modulus, in.<sup>3</sup> (mm<sup>3</sup>)

$F_{cr}$  =  $F_{crx}$ , ksi (MPa)

$F_{crx}$  = nominal axial compressive stress in ksi (MPa) based on  $k\ell/r_x$ ,

where  $\ell$  is the length,  $k$  is the effective length factor, and  $r_x$  is the corresponding radius of gyration of the member as defined in Section 4.3

$F_{crz}$  = nominal axial compressive stress in ksi (MPa) based on  $k\ell/r_z$

where  $k = 1.0$

$C_m$  = 1.0

$F_y$  = specified minimum yield strength, ksi (MPa)

$F'_e$  =  $\frac{\pi^2 E}{(k\ell/r_x)^2}$ , ksi (MPa)

$Q$  = form factor defined in Section 4.2.2.2

Alternate methods of design shall be permitted provided they provide strength equal to or greater than those given. Alternate design procedures shall be submitted to the Steel Joist Institute's consulting engineer for approval.

#### 4.4.3 Fillers and Ties

Fillers or ties added on chord or web compression members shall be designed and connected for a force equal to two percent of the required member axial force.

#### 4.4.4 Joist Extensions

**CJ-Series** joist extensions shall be designated as one of three extension types, as follows: top chord extensions (TCX), extended ends, or full depth cantilevers.

Design criteria for **CJ-Series** joist extensions shall be specified using one of the following methods:

- (1) A **CJ-Series** joist top chord extension (TCX), extended end, or full depth cantilevered end shall be designed for the load based on the design length and designation of the specified **CJ-Series** joist. In the absence of other design information, the joist manufacturer shall design the joist extension for this loading as a default.
- (2) A loading diagram shall be provided for the **CJ-Series** joist extension, extended end, or full depth cantilevered end. The diagram shall include the magnitude and location of the loads to be supported, as well as the applicable load combinations.

Any deflection requirements or limits due to the accompanying loads and load combinations on the **CJ-Series** joist extension shall be provided by the specifying professional, regardless of the method used to specify the extension. Unless otherwise specified, the joist manufacturer shall check the extension for the specified deflection limit under uniform live load acting simultaneously on both the **CJ-Series** joist base span and the extension.

The joist manufacturer shall consider the effects of **CJ-Series** joist extension loading on the base span of the steel joist. This shall include carrying the design bending moment due to the loading on the extension into the top chord end panel(s), and the effect on the overall steel joist chord and web axial forces. The joist extension shall support all end loads without relying on any composite action.

Required bracing of extensions shall be clearly indicated on the structural drawings.

Design of concrete reinforcing steel in the negative moment region shall be the responsibility of the specifying professional.

## 4.5 CONNECTIONS

### 4.5.1 Methods

Member connections and splices shall be made by attaching the members to one another by arc or resistance welding or other accredited methods in accordance with the following:

- a) CJ-Series joist arc welded joints shall be in accordance with the American Welding Society, "Structural Welding Code-Steel", D1.1, and/or the "Structural Welding Code Sheet Steel", D1.3 with the following eight modified acceptance criteria as permitted by AWS D1.1 Clause 6.8:

1. Undercut shall not exceed 1/16 inch (2 mm) for welds oriented parallel to the principal stress.

**User Note:** The typical diagonal web member connection to one leg of a chord angle is considered to be parallel to the principal stress.

2. Discontinuities outside of the weld design length shall be permitted provided no cracks exist and undercut does not exceed the limits of item 1.

**User Note:** The weld design length is the minimum weld length needed for the connection force and weld thickness. Portions of the actual weld length with imperfections or discontinuities such as porosity or lack of a full profile are not included when comparing the actual weld length to the weld design length.

3. One unrepaired arc strike shall be permitted per joint provided it does not result in other unacceptable defects.

**User Note:** Minor arc strikes do not reduce the strength of AWS Group II materials (refer to Van Malsen, 1984).

4. The effective throat for flare bevel groove welds shall be calculated in accordance with equation 4.2-12.

**User Note:** The effective weld throat used by the SJI with round bars is based on SJI research and is more conservative than AWS D1.1 for GMAW for round bars in excess of 9/16" (14 mm). See Steel Joist Institute Technical Digest 8 - Welding of Open Web Steel Joists and Joist Girders.

5. Tack welds that are discontinuous from other welds shall meet the criteria for undercut, but shall be exempt from all other acceptance criteria.

**User Note:** Joist manufacturers use tack welds in the assembly process, and so long as they do not diminish the strength of the base metal and are not incorporated into the final weld for strength, they are not required to meet other inspection criteria.

6. The weld profile shall be considered acceptable provided neither the weld leg nor the weld throat is undersized less than AWS D1.1 limits within the weld design length.

7. For material with thickness less than 1/8", AWS D1.1 or D1.3 shall be considered appropriate.

**User Note:** AWS D1.1 does not address thicknesses less than 1/8" for hot rolled material and AWS D1.3 does not address hot rolled material, thus SJI has extended the ranges to include these material thicknesses.

8. A ratio of stud diameter to top chord thickness of up to 3.0 shall be permitted.

**User Note:** See section 4.5.4 Shear Studs for reduction in stud capacity for ratios between 2.7 and 3.0.

- b) CJ-Series joist resistance welded joints shall follow a preproduction validation procedure and a production checking procedure and shall meet the strength requirements of this Specification.

**User Note:** Spot, flash or upset resistance welds should have a written welding procedure qualification record and a systematic quality plan. For further information, see Steel Joist Institute Technical Digest 8 - Welding of Open Web Steel Joists and Joist Girders.

- c) Welded Connections for Crimped-End Angle Web Members

- 1) The connection of each end of a crimped angle web member to each side of the chord shall consist of a weld group made of more than a single line of weld. The design weld length shall include an end return of no less than two times the nominal weld size.

- d) Welding Program

- 1) The manufacturer's welders shall be qualified in accordance with either AWS D1.1 or AWS D1.3 for the applicable weld type, position, and material.
- 2) Manufacturers shall have a program for establishing weld procedures and operator qualification, and for weld sampling and testing. Each manufacturing facility shall have trained inspectors, and an engineer responsible for all welding procedures.

- e) Weld Inspection by Outside Agencies (See Section 5.14)

- 1) The agency shall arrange for visual inspection to determine that welds meet the acceptance standards of Section 4.5.1.

**User Note:** Ultrasonic, X-ray, and magnetic particle testing are inappropriate for joists due to the configurations of the components and welds.

## 4.5.2 Strength

**4.5.2.1 Joint Connections:** Joint connections shall develop the maximum force due to any of the design loads, but not less than 50 percent of the strength of the member in tension or compression, whichever force is the controlling factor in the selection of the member.

**4.5.2.2 Shop Splices:** Shop splices shall be permitted to occur at any point in chord or web members. Splices shall be designed for the member force, but not less than 50 percent of the member strength. All component parts comprising the cross section of the chord or web member (including reinforcing plates, rods, etc.) at the point of the splice shall develop a nominal tensile strength of at least 1.2 times the product of the yield strength and the full design area of the chord or web. The "full design area" shall be defined as the minimum required area such that the required stress will be less than the design (LRFD) stress.

**User Note:** For more information on welding, see Steel Joist Institute Technical Digest 8 - Welding of Open Web Steel Joists and Joist Girders.

## 4.5.3 Field Splices

Field Splices shall be designed by the manufacturer and shall be either bolted or welded. Splices shall be designed for the member force, but not less than 50 percent of the member strength.

**4.5.4 Shear Studs**

Shear studs, after installation, shall extend not less than 1½ in. (38 mm) above the top of the steel deck and there shall be at least ½ in. (13 mm) of concrete cover above the top of the installed studs.

For studs in 1.5 in. (38 mm), 2 in. (51 mm), or 3 in. (76 mm) deep decks with  $d_{stud}/t_{top\ chord} \leq 2.7$ :

$$Q_n = \text{Min} \left[ 0.5A_{stud} \sqrt{f'_c E_c} , R_p R_g A_{stud} F_{u\ stud} \right] \text{ (kips)} \quad (4.5-1a)$$

$$Q_n = \text{Min} \left[ 0.5A_{stud} \sqrt{f'_c E_c} , (R_p R_g A_{stud} F_{u\ stud} / 1000) \right] \text{ (kN)} \quad (4.5-1b)$$

For studs in 1.5 in. (38 mm), 2 in. (51 mm), or 3 in. (76 mm) deep decks with  $2.7 < d_{stud}/t_{top\ chord} \leq 3.0$ :

$$Q_n = \text{Min} \left[ 0.5A_{stud} \sqrt{f'_c E_c} , R_p R_g A_{stud} F_{u\ stud} - 1.5 \left( \frac{d_{stud}}{t_{top\ chord}} - 2.7 \right) \right] \text{ (kips)} \quad (4.5-2a)$$

$$Q_n = \text{Min} \left[ 0.5A_{stud} \sqrt{f'_c E_c} , (R_p R_g A_{stud} F_{u\ stud} / 1000) - 6.67 \left( \frac{d_{stud}}{t_{top\ chord}} - 2.7 \right) \right] \text{ (kN)} \quad (4.5-2b)$$

Where:

- $A_{stud}$  = cross-sectional area of shear stud, in.<sup>2</sup> (mm<sup>2</sup>)
- $d_{stud}$  = diameter of shear stud, in. (mm)
- $E_c$  = modulus of elasticity of the concrete, ksi (MPa)
- $f'_c$  = specified compressive strength of concrete, ksi (MPa)
- $F_{u\ stud}$  = minimum tensile strength of stud, 65 ksi (450 MPa)
- $Q_n$  = shear capacity of a single shear stud, kips (kN)
- $R_p$  = shear stud coefficient from Table 4.5-1
- $R_g$  = 1.00 for one stud per rib or staggered position studs  
= 0.85 for two studs per rib side-by-side  
= 0.70 for three studs per rib side-by-side
- $t_{top\ chord}$  = thickness of top chord horizontal leg or flange, in. (mm)

**TABLE 4.5-1  
VALUES FOR  $R_p$**

Metal Deck Height	Wr @ mid-height	Diameter Stud			
		¾ in. (10 mm)	½ in. (13 mm)	⅝ in. (16 mm)	¾ in. (19 mm)
1 in. (25 mm)	1.9 in. (48 mm)	0.55	0.55	0.50	0.45
1.5 in. (38 mm)	2.1 in. (53 mm)	0.55	0.50	0.45	0.40
1.5 in. (38 mm) Inverted	3.9 in. (99 mm)	0.85	0.60	0.60	0.60
2 in. (51 mm)	6 in. (152 mm)	---	0.55	0.50	0.45
3 in. (76 mm)	6 in. (152 mm)	---	0.50	0.50	0.50

Notes:  $W_r$  @ mid-height = Average metal deck rib width of deck rib containing the shear stud.  
The deck is assumed to be oriented perpendicular to the joists.

#### 4.5.5 Eccentricity

Members connected at a joint shall have their center of gravity lines meet at a point, where practical. Ends of **CJ-Series** joists shall be proportioned to resist bending produced by eccentricity at the support.

For a single component web member, the eccentricity shall be permitted to be neglected where it does not exceed the lesser of three-quarters of the overall dimension of the chord or 2 inches (51 mm). This eccentricity, measured in the plane of the joist, shall be the perpendicular distance from the centroidal axis of that web member to the point on the centroidal axis of the chord which is vertically above or below the intersection of the centroidal axis of the web member(s) forming the joint in accordance with Figure 4.5-1.

For a web member composed of at least two shapes, the eccentricity on either side of the neutral axis of chord members, measured in the plane of the **CJ-Series** joist at the joint work point, shall be permitted to be neglected where the web intersection point does not exceed one and one-half times the distance between the neutral axis and the back of the chord in accordance with Figure 4.5-2.

If these limits are exceeded, provision shall be made for the stresses due to eccentricity.

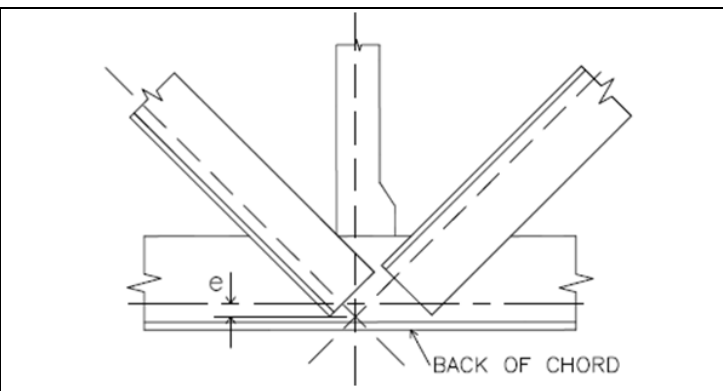
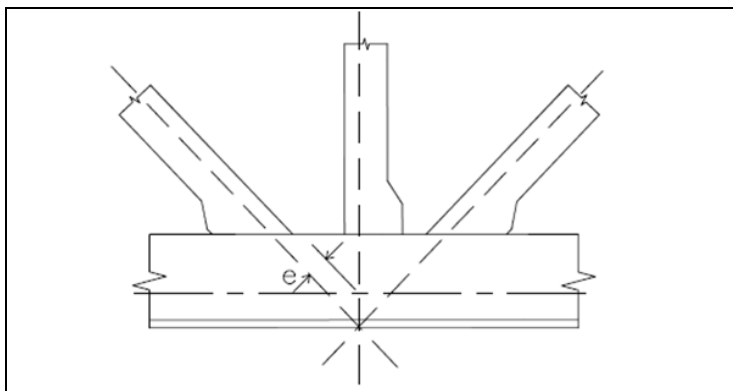

Figure 4.5-1 Single Angle Web Members and Bottom Chord Workpoint Eccentricity

Figure 4.5-2 Multiple Web Members and Bottom Chord Workpoint Eccentricity

#### 4.6 CAMBER

**CJ-Series** joists shall be cambered. The approximate camber shall be based on the deflection associated with 100 percent of the non-composite unfactored dead load plus any additional loads defined by the specifying professional.

**User Note:** The specifying professional shall give consideration to coordinating this approximate camber with adjacent framing.

#### 4.7 VERIFICATION OF DESIGN AND MANUFACTURE

**User Note:** This Section is included as part of this Specification since the verification of design and manufacture is a requirement of any Steel Joist Institute member company in order to be in compliance with this Specification. This Section applies only to a Steel Joist Institute member manufacturer.

##### 4.7.1 Design Calculations

Companies manufacturing any **CJ-Series** Joists shall submit design data to the Steel Joist Institute, or an independent agency approved by the Steel Joist Institute, for verification of compliance with this Specification. Design data shall be submitted in detail and in the format specified by the Steel Joist Institute.

##### 4.7.2 Tests of Chord and Web Members

Each manufacturer shall, at the time of design review by the Steel Joist Institute, verify by tests that the design, in accordance with Section 4.1 through Section 4.5, provides the theoretical strength of critical members. Such tests shall be evaluated considering the actual yield strength of the members of the test **CJ-Series** joists.

Material tests for determining mechanical properties of component members shall be conducted.

#### 4.7.3 Tests of Joints and Connections

Each manufacturer shall, at the time of design review by the Steel Joist Institute, verify by shear tests on representative joints of typical **CJ-Series** joists that connections will meet the provision of Section 4.5.2. Chord and web members shall be permitted to be reinforced for such tests.

#### 4.7.4 In-Plant Inspections

Each manufacturer shall verify their ability to manufacture **CJ-Series** joists through periodic In-Plant Inspections. Inspections shall be performed by an independent agency approved by the Steel Joist Institute. The frequency, manner of inspection and manner of reporting shall be determined by the Steel Joist Institute. The Plant inspections shall not represent a guarantee of the quality of any specific **CJ-Series** joists; this responsibility shall lie fully and solely with the individual manufacturer.

## SECTION 5. APPLICATION

### 5.1 USAGE

**5.1.1 Scope:** This Specification shall apply to any type of structure where floors or roofs are to be supported directly by **CJ-Series** joists installed as hereinafter specified. Where **CJ-Series** joists are used other than on simple spans under uniformly distributed loading for **CJ-Series** joists, as prescribed in Section 4.1, they shall be designed to limit the required stresses to those listed in Section 4.2. The magnitude and location of all loads and forces to be considered in the **CJ-Series** joist design shall be provided on the structural drawings.

**5.1.2 Continuous Frame Action:** Where a rigid connection of the bottom chord is to be made to a column or other structural support, the **CJ-Series** steel joist is then no longer simply-supported, and the system shall be investigated for continuous frame action by the specifying professional. The specifying professional shall design the supporting structure, including the design of columns, connections, and moment plates. This design shall account for the stresses caused by lateral forces and the stresses due to connecting the bottom chord to the column or other structural support.

The designed detail of a rigid type connection and moment plates shall be shown on the structural drawings by the specifying professional. The moment plates shall be furnished by other than the joist manufacturer.

**User Note:** For further reference concerning continuous frame action and their connections, refer to Steel Joist Institute Technical Digest No. 11, "Design of Lateral Load Resisting Frames Using Steel Joists and Joist Girders".

### 5.2 SPAN

The span of a **CJ-Series** joist shall not be less than 12 times nor exceed 30 times the depth. Design length shall equal the span minus 4 inches (102 mm) as shown in Figure 5.2-1 "Definition of Span".

### 5.3 DEPTH



**CJ-Series** joists shall have parallel chords. The composite joist designation depth or nominal depth shall be the vertical distance from the top of the steel top chord to the bottom of the bottom chord.

#### **5.4 END SUPPORTS**

Consideration of the reactions, vertical and lateral, shall be taken by the specifying professional in the design of the steel support, or the steel bearing plate on masonry or concrete. The standard location of the end reaction shall be 2 inches (51 mm) from the end of the span (exclusive of extensions) at each end of the **CJ-Series** joist as shown in Figure 5.2-1 "Definition of Span".

The standard **CJ-Series** joist bearing seat depth, clear bearing length, minimum bearing plate width and minimum bearing length on steel is provided in Table 5.4-1.

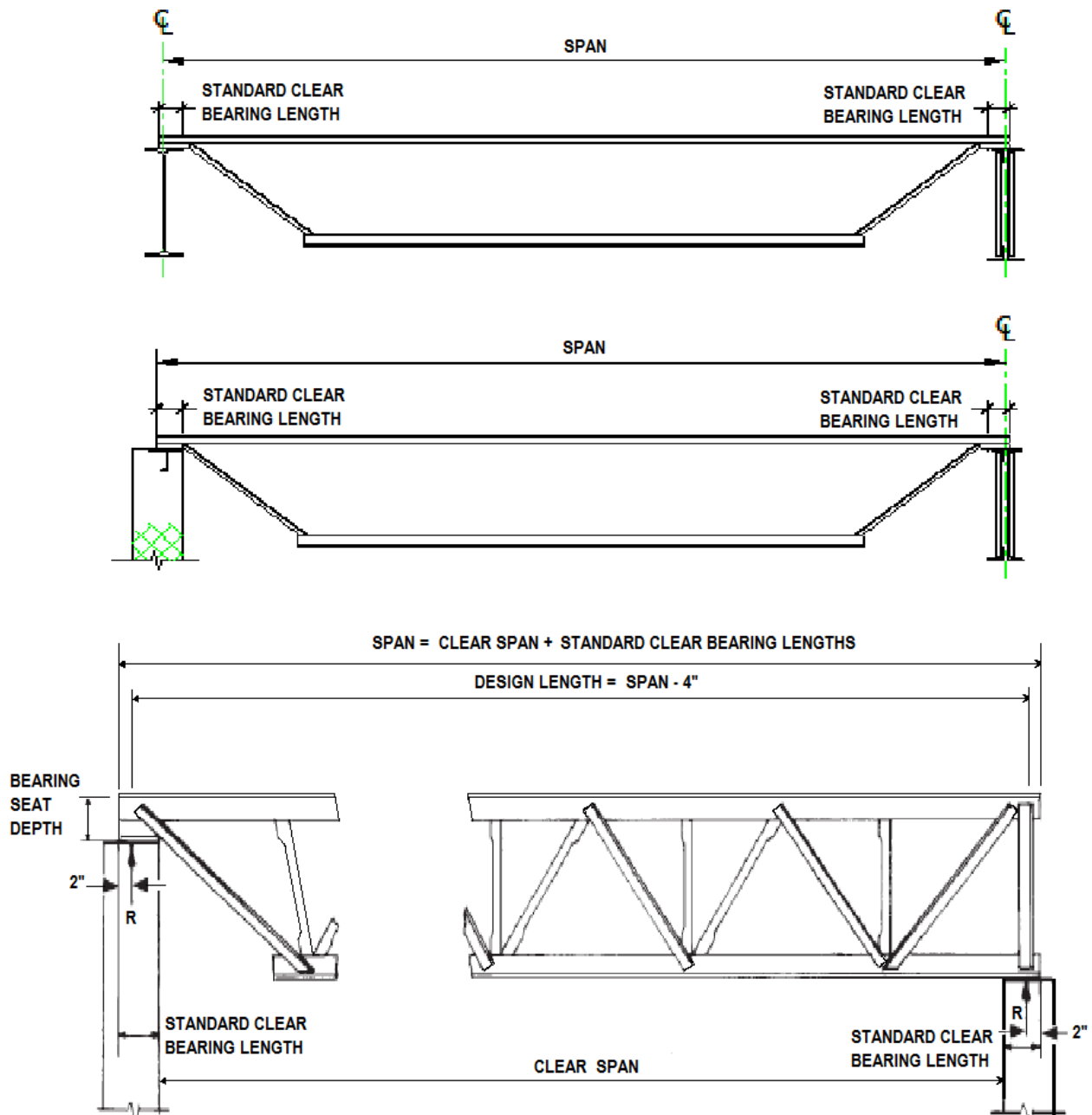

**NOTES:**

- 1) DESIGN LENGTH = SPAN - 4"
- 2) MINIMUM BEARING LENGTHS SHALL MEET THE REQUIREMENTS OF SECTION 5.4; BEARING LENGTHS SHOWN MAY VARY BETWEEN STANDARD CLEAR BEARING AND MINIMUM BEARING LENGTH.
- 3) PARALLEL CHORD CJ-SERIES JOISTS INSTALLED TO A SLOPE GREATER THAN 1/2 INCH PER FOOT SHALL USE A SPAN DEFINED BY THE LENGTH ALONG THE SLOPE.

Figure 5.2-1 Definition of Span (U.S. Customary Units)

**TABLE 5.4-1**

GENERAL DESCRIPTION OF CJ-SERIES JOIST TOP CHORD	STANDARD BEARING SEAT DEPTH	STANDARD CLEAR BEARING LENGTH	MINIMUM BEARING PLATE WIDTH	MINIMUM BEARING LENGTH ON STEEL
Where round web end bars are used and the top chord vertical angle leg is less than or equal to 2"	2½" (64 mm)	4" (102 mm)	6" (178 mm)	2½" (64 mm)
Where the top chord vertical angle leg is greater than 2", but less than 3½"	5" (127 mm)	6" (152 mm)	9" (229 mm)	4" (102 mm)
Where the top chord vertical angle leg is greater than or equal to 3½"	7½" (191 mm)	6" (152 mm)	14" (356 mm)	6" (152 mm)

If the specifying professional requires the end reaction to be located at a distance from the face of support more than the standard clear bearing length values shown in Table 5.4-1 minus 2 in. (51 mm), the structural drawings shall indicate the required special location of the end reaction. The **CJ-Series** joist seat depth shall be increased proportionately.

### 5.4.1 Masonry and Concrete

**5.4.1.1 Scope:** **CJ-Series** joists supported by masonry or concrete shall bear on steel bearing plates and shall be designed as steel bearing. Consideration of the end reactions and all other vertical and lateral forces shall be taken by the specifying professional in the design of the steel bearing plate and the masonry or concrete.

The ends of **CJ-Series** joists shall extend over the masonry or concrete support as shown in Figure 5.2-1 and be anchored to a steel bearing plate.

The steel bearing plate shall be located not more than ½ inch (13 mm) from the face of the wall. If the steel bearing plate is located more than ½ inch (13 mm) from the face of the wall, or the minimum bearing over the masonry or concrete support cannot be provided as given in Table 5.4-1, special consideration shall be given to the design of the steel bearing plate and the masonry or concrete by the specifying professional.

The steel bearing plate is to be designed by the specifying professional and shall be furnished by other than the joist manufacturer.

**5.4.1.2 Anchorage:** **CJ-Series** joists shall be anchored to the steel bearing plate per Section 5.7.

### 5.4.1.3 Composite Joist Bearing Seat

For 2½" ≤ Seat Depth < 5":

- a) The ends of **CJ-Series** joists shall extend a distance of not less than 4 inches (102 mm) over the masonry or concrete support and be anchored to the steel bearing plate.
- b) The width of the plate perpendicular to the span of the **CJ-Series** joist shall be not less than 6 inches (152 mm).
- c) The **CJ-Series** joist shall bear a minimum of 2½ inches (64 mm) on the steel bearing plate.

For 5" ≤ Seat Depth < 7½":

- a) The ends of **CJ-Series** joists shall extend a distance of not less than 6 inches (152 mm) over the masonry or concrete support and be anchored to the steel bearing plate.
- b) The width of the plate perpendicular to the span of the **CJ-Series** joist shall be not less than 9 inches (229 mm).
- c) The **CJ-Series** joist shall bear a minimum of 4 inches (102 mm) on the steel bearing plate.

For Seat Depth  $\geq 7\frac{1}{2}$ ":

- a) The ends of **CJ-Series** joists shall extend a distance of not less than 6 inches (152 mm) over the masonry or concrete support and be anchored to the steel bearing plate.
- b) The width of the plate perpendicular to the span of the **CJ-Series** joist shall be not less than 14 inches (356 mm).
- c) The **CJ-Series** joist shall bear a minimum of 6 inches (152 mm) on the steel bearing plate.

#### 5.4.2 Steel

**5.4.2.1 Scope:** **CJ-Series** joists supported directly by steel supporting members shall be designed as steel bearing.

**User Note:** Due consideration of the end reactions and all other vertical and lateral forces shall be taken by the specifying professional in the design of the steel support.

**5.4.2.2 Anchorage:** **CJ-Series** joists shall be anchored to steel supporting members per Section 5.7.

#### 5.4.2.3 CJ-Series Joist Bearing Seat

For  $2\frac{1}{2}$ "  $\leq$  Seat Depth  $< 5$ ": The ends of **CJ-Series** joists shall extend a distance of not less than  $2\frac{1}{2}$  inches (64 mm) over the steel supports.

For  $5$ "  $\leq$  Seat Depth  $< 7\frac{1}{2}$ ": The ends of **CJ-Series** joists shall extend a distance of not less than 4 inches (102 mm) over the steel supports.

For Seat Depth  $\geq 7\frac{1}{2}$ ": The ends of **CJ-Series** joists shall extend a distance of not less than 6 inches (152 mm) over the steel supports.

Where deemed necessary to butt opposite joists over a narrow steel support with bearing less than that noted above, special ends shall be specified, and such ends shall have positive attachment to the support, either by bolting or welding.

### 5.5 BRIDGING OR BRACING

**CJ-Series** joist top and bottom chord bridging shall be required and shall consist of one or both of either horizontal or diagonal bridging.

**User Note:** See Section 5.12 for bridging or bracing required for uplift forces.

#### 5.5.1 Horizontal Bridging

Horizontal bridging lines shall consist of continuous horizontal steel members. The  $\ell/r$  ratio of the bridging member shall not exceed 300, where  $\ell$  is the distance in inches (mm) between attachments and  $r$  is the least radius of gyration of the bridging member.

#### 5.5.2 Diagonal Bridging

Diagonal bridging lines shall consist of cross-bracing with an  $\ell/r$  ratio of not more than 200, where  $\ell$  is the distance in inches (mm) between connections and  $r$  is the least radius of gyration of the bracing member. Where cross-bracing members are connected at their point of intersection, the  $\ell$  distance shall be taken as the distance in inches (mm) between connections at the point of intersection of the bridging members and the connections to the chords of the **CJ-Series** steel joists.

### 5.5.2.1 Diagonal Erection Bridging

**User Note:** CJ-Series joists exhibit varying degrees of stability dependent upon the span, depth, member sizes, self-weight and other parameters. Bolted diagonal Erection Bridging which must be installed prior to releasing hoisting cables may be required.

Where required, bolted diagonal Erection Bridging shall be provided in accordance with the following:

- a) For CJ-Series joist spans up through and including 60 feet (18.3 m) in length, welded horizontal bridging shall be permitted to be used except where the row of bridging nearest the center is required to be bolted diagonal Erection Bridging as indicated on the joist manufacturer's joist placement plans.

The stability of the CJ-Series joist and the need for Erection Bridging shall be determined using Equation 5.5-1.

Erection Bridging is required if,

$$\frac{w_u}{W_{actual}} \leq 1.00 \quad (5.5-1)$$

Where:

$W_{actual}$  = CJ-Series joist self-weight, plf (kN/m)

$w_u$  = ultimate lateral buckling load,  $w_u = \frac{W \cdot I2}{L}$  plf  $w_u = \frac{W}{L}$  (kN/m)

$$W = \frac{-b + \sqrt{b^2 - 4 \cdot a \cdot c}}{2 \cdot a}$$

$$a = \left( \frac{\pi^2 + 3}{24} \right)^2$$

$$b = P \cdot \frac{\pi^2 + 3}{12} \cdot \frac{\pi^2 + 4}{16} - \frac{\pi^4 \cdot E \cdot I_y}{2 \cdot (k \cdot L)^3} \cdot \left[ \beta_x \cdot \left( \frac{\pi^2 - 3}{24} \right) - \frac{y_o}{2} \right]$$

$$c = (P)^2 \left( \frac{\pi^2 + 4}{16} \right)^2 - \frac{\pi^4 \cdot E \cdot I_y}{2 \cdot (k \cdot L)^3} \cdot \left[ P \cdot \left( \beta_x \cdot \frac{\pi^2 - 4}{16} - a_e \right) + \frac{\pi^4 \cdot E \cdot C_w}{2 \cdot (k \cdot L)^3} + \frac{\pi^2 \cdot G \cdot J}{2 \cdot k \cdot L} \right]$$

$A_b$  = area of non-composite joist bottom chord, in.<sup>2</sup> (mm<sup>2</sup>)

$A_t$  = area of non-composite joist top chord, in.<sup>2</sup> (mm<sup>2</sup>)

$C_w$  = warping constant  $C_w = \frac{d_e^2 \cdot I_{yb} \cdot I_{yt}}{I_y}$

$E$  = modulus of elasticity = 29,000,000 psi (200,000 MPa)

$G$  = shear modulus, psi (MPa)  $G = 0.385E$

$I_x$  = non-composite joist moment of inertia about x-axis, in.<sup>4</sup> (mm<sup>4</sup>)  $I_x = A_t y^2 + A_b (d_e - y)^2$

$I_y$  = joist moment of inertia about y-axis, in.<sup>4</sup> (mm<sup>4</sup>)  $I_y = I_{yt} + I_{yb}$

$I_{yb}$  = bottom chord moment of inertia about y-axis, in.<sup>4</sup> (mm<sup>4</sup>)

$I_{yt}$  = top chord moment of inertia about y-axis, in.<sup>4</sup> (mm<sup>4</sup>)

- $J$  = St. Venant torsion constant, in.<sup>4</sup> (mm<sup>4</sup>)  $J = \frac{1}{3}(A_t \cdot t_t^2 + A_b \cdot t_b^2)$
- $L$  = joist span, in. (mm)
- $P$  = factored weight of erector = 1.2 x (assumed weight of 250 lbs.) = 300 lbs (1334 N)
- $a_e$  = vertical location of load P from shear center (locate at non-composite joist center of gravity), in. (mm), where  $a_e = y_o$
- $\beta_x$  = cross-sectional parameter  $\beta_x = \frac{1}{I_x} [A_b \cdot (d_e - y)^3 - A_t \cdot y^3] - 2 \cdot y_o$
- $d_e$  = non-composite joist effective depth, in.(mm)  $d_e = d - y_t - y_b$
- $k$  = effective length factor = 0.85
- $t_b$  = thickness of top chord, in. (mm)
- $t_t$  = thickness of top chord, in. (mm)
- $y$  = distance from centroid of top chord to centroid of cross section, in. (mm)  $y = \frac{A_b \cdot d_e}{A_t + A_b}$
- $y_o$  = distance from centroid of cross section to shear center, in. (mm)  $y_o = -y + \frac{I_{yb} \cdot d_e}{I_y}$
- $y_t$  = neutral axis of non-composite joist top chord, in. (mm)
- $y_b$  = neutral axis of non-composite joist bottom chord, in. (mm)

- b) For joist spans over 60 feet (18.3 meters) all rows of bridging shall be diagonal bridging with bolted connections at the chords and intersections as indicated on the joist manufacturer's joist placement plans. Where the **CJ**-Series joist spacing is less than 0.70 x joist depth, bolted horizontal bridging shall be used in addition to bolted diagonal Erection Bridging.
- c) The bolted diagonal Erection Bridging determined by Section 5.5.2 shall be considered a minimum. This bolted diagonal Erection Bridging shall be indicated on the joist manufacturer's joist placement plans.

### 5.5.3 Quantity and Spacing of Bridging

**5.5.3.1 Scope:** Bridging shall be properly spaced and anchored to support the metal decking and the employees prior to the attachment of the deck to the top chord. The maximum spacing between lines of bridging,  $\ell_{brmax}$  shall be the lesser of,

$$\ell_{brmax} = \left( 100 + 0.67 d_j + 40 \frac{d_j}{L} \right) r_y, \text{ in.} \tag{5.5-2a}$$

$$\ell_{brmax} = \left( 100 + 0.026 d_j + 0.48 \frac{d_j}{L} \right) r_y, \text{ mm} \tag{5.5-2b}$$

or,

$$\ell_{brmax} = 170 r_y \tag{5.5-3}$$

Where:

- $d_j$  = **CJ**-Series joist depth, in. (mm)
- $L$  = **CJ**-Series joist span length, ft. (m)
- $r_y$  = radius of gyration of the top chord about the vertical axis of the joist cross section, in. (mm)

**5.5.3.2 Number of Rows:** The number of rows of bottom chord bridging, including bridging required per Section 5.12, shall not be less than the number of top chord rows. Rows of bottom chord bridging shall be permitted to be spaced independently of rows of top chord bridging. The spacing of rows of bottom chord bridging shall meet the slenderness requirement of Section 4.3 and any specified strength requirements.

**5.5.4 Sizing of Bridging**

Horizontal and diagonal bridging shall be capable of resisting the nominal unfactored horizontal compressive force,  $P_{br}$  given in Equation 5.5-4.

$$P_{br} = 0.0025 n A_t F_{construction}, \text{ kips (N)} \tag{5.5-4}$$

Where:

$n$  = 8 for horizontal bridging

$n$  = 2 for diagonal bridging

$A_t$  = cross-sectional area of joist top chord, in.<sup>2</sup> (mm<sup>2</sup>)

$F_{construction}$  = assumed ultimate stress in top chord to resist construction loads, determined in accordance with the following:

$$F_{construction} = \frac{\pi^2 E}{\left(\frac{0.9 \ell_{brmax}}{r_y}\right)^2} \geq 12.2 \text{ ksi} \tag{5.5-5a}$$

$$F_{construction} = \frac{\pi^2 E}{\left(\frac{0.9 \ell_{brmax}}{r_y}\right)^2} \geq 84.1 \text{ MPa} \tag{5.5-5b}$$

Where:

$E$  = modulus of elasticity = 29,000 ksi (200,000 MPa)

and  $\frac{\ell_{brmax}}{r_y}$  is determined from Equations 5.5-2 or 5.5-3

**5.5.5 Connections**

Connections to the **CJ-Series** joist chords shall be made by welding or mechanical means and shall be capable of resisting the unfactored or nominal horizontal force,  $P_{br}$ , of Equation 5.5-4 but not less than 700 pounds (3114 N).

**5.5.6 Bottom Chord Bearing CJ-Series Joists**

Where bottom chord bearing **CJ-Series** joists are utilized, a row of diagonal bridging shall be provided near the support(s). This bridging shall be installed and anchored before the hoisting cable(s) is released.

**5.6 INSTALLATION OF BRIDGING**

Bridging shall be provided to support the top chord of **CJ-Series** joists during installation of the metal decking prior to the attachment of the deck to the top chord. All bridging and bridging anchors shall be completely installed before construction loads are placed on the **CJ-Series** joists. Bridging shall support the top and bottom chords against lateral movement during the construction period and shall hold the **CJ-Series** joists in the approximate position as shown on the joist placement plans. The ends of all bridging lines terminating at walls or beams shall be anchored thereto.

## 5.7 BEARING SEAT ATTACHMENTS

### 5.7.1 Masonry and Concrete

Ends of **CJ-Series** steel joists resting on steel bearing plates on masonry or structural concrete shall be attached as defined by the following criteria:

For  $2\frac{1}{2}" \leq \text{Seat Depth} < 5"$ : With a minimum of two  $\frac{1}{8}$  inch (3 mm) fillet welds 2 inches (51 mm) long, or with two  $\frac{1}{2}$  inch (13 mm) ASTM A307 bolts, or with the equivalent.

For Seat Depth  $\geq 5"$ : With a minimum of two  $\frac{1}{4}$  inch (6 mm) fillet welds 2 inches (51 mm) long, or with two  $\frac{3}{4}$  inch (19 mm) ASTM A307 bolts or the equivalent.

### 5.7.2 Steel

Ends of **CJ-Series** joists resting on steel supports shall be attached as defined by the following criteria:

For  $2\frac{1}{2}" \leq \text{Seat Depth} < 5"$ : With a minimum of two  $\frac{1}{8}$  inch (3 mm) fillet welds 2 inches (51 mm) long, or with two  $\frac{1}{2}$  inch (13 mm) ASTM A307 bolts, or with the equivalent.

For Seat Depth  $\geq 5"$ : With a minimum of two  $\frac{1}{4}$  inch (6 mm) fillet welds 2 inches (51 mm) long, or with two  $\frac{3}{4}$  inch (19 mm) ASTM A307 bolts, or with the equivalent.

In steel frames, where columns are not framed in at least two directions with solid structural steel members, **CJ-Series** joists at column lines shall be field bolted and the joist bottom chords shall be restrained by a vertical stabilizer plate attached to the column providing lateral stability during construction. Where constructability does not allow a **CJ-Series** joist to be installed directly at the column, an alternate means of stabilizing the joist shall be installed on both sides near the column (CFR). When **CJ-Series** joists are used to provide lateral stability to the supporting member, the final connection shall be made by welding or as designated by the specifying professional.

### 5.7.3 Uplift

Where uplift forces are a design consideration, **CJ-Series** joists used in roof applications shall be anchored to resist such forces and shall meet the requirements of Section 5.12.

## 5.8 JOIST SPACING

**CJ-Series** joists shall be spaced so that the loading on each joist does not exceed the design load (LRFD).

## 5.9 DECKS

### 5.9.1 Material

Floor deck shall consist of steel deck or other suitable material capable of supporting the required load at the specified **CJ-Series** joist spacing.

### 5.9.2 Thickness

Cast-in-place slabs shall be not less than 2 inches (51 mm) thick.

### 5.9.3 Centering

Centering for cast-in-place slabs shall be permitted to be a suitable material capable of supporting the slab at the designated **CJ-Series** joist spacing.

Centering shall not cause lateral displacement or damage to the top chord of **CJ-Series** joists during installation or removal of the centering or placing of the concrete.



#### 5.9.4 Bearing

Slabs or decks shall bear uniformly along the top chords of the **CJ-Series** joists.

#### 5.9.5 Attachments

The decking shall be attached per Steel Deck Institute requirements prior to placing construction loads on the **CJ-Series** joists. The spacing of attachments along the **CJ-Series** joist top chord shall not exceed 36 inches (914 mm).

#### 5.10 DEFLECTION

The deflection due to the design live load shall not exceed the following:

Floors: 1/360 of span

Roofs: 1/360 of span where a plaster ceiling is attached or suspended, or 1/240 of span for all other cases.

The specifying professional shall give consideration to the effects of deflection and vibration in the selection of **CJ-Series** steel joists.

**User Note:** For further information on vibration, refer to Steel Joist Institute Technical Digest 5, "Vibration of Steel Joist-Concrete Slab Floors".

#### 5.11 PONDING

The ponding investigation shall be performed by the specifying professional.

**User Note:** For further reference, refer to Steel Joist Institute Technical Digest 3, "Structural Design of Steel Joist Roofs to Resist Ponding Loads" and AISC 360.

#### 5.12 UPLIFT

Where uplift forces due to wind are a design requirement, these forces shall be indicated on the structural drawings in terms of net uplift in pounds per square foot (Pascals). When these forces are specified, they shall be considered in the design of **CJ-Series** steel joists, and required bridging or bracing. A single line of bottom chord bridging shall be provided near the first bottom chord panel points wherever uplift due to wind forces is a design consideration.

**User Note:** For further reference, refer to Steel Joist Institute Technical Digest 6, "Structural Design of Steel Joist Roofs to Resist Uplift Loads".

#### 5.13 DIAPHRAGMS AND COLLECTORS

Where diaphragm collector forces due to wind or seismic forces are a design requirement, these nominal (unfactored) forces shall be indicated on the structural drawings. The structural drawings shall also indicate the Seismic Design Category, and the Seismic Force Resisting System type, and applicable seismic design coefficients. When this data is specified, joist collectors or chords in horizontal diaphragm systems, shall be designed in conformance with the provisions of Section 4 through Section 6. End connections and splices in **CJ-Series** steel joists incorporated into Seismic Force Resisting System (SFRS) as horizontal diaphragms as collectors or chords shall adhere to the requirements stipulated by the applicable building code.

#### 5.14 INSPECTION

**CJ-Series** joists shall be inspected by the manufacturer before shipment to verify compliance of materials and workmanship with the requirements of this Specification.

**User Note:** If the purchaser requires an inspection of the **CJ-Series** joists by someone other than the manufacturer's own inspectors, they shall be permitted to reserve the right to do so in their "Invitation to Bid" or the accompanying "Job Specifications". Arrangements shall be made with the manufacturer for such inspection of the **CJ-Series** joists at the manufacturing facility by the purchaser's inspectors at purchaser's expense.

## SECTION 6

# ERECTION STABILITY AND HANDLING

As a minimum, erection stability and handling of **CJ-Series** steel joists shall meet the requirements of this Section 6.

**User Note:** Additional requirements for erection of **CJ-Series** steel joists can be found in Steel Joist Institute Technical Digest 9, "Handling and Erection of Steel Joists and Joist Girders".

### 6.1 STABILITY REQUIREMENTS

**User Note:** It is not recommended that an erector climb on unbridged joists, extreme caution shall be exercised since unbridged joists exhibit some degree of instability under the erector's weight.

- a) In steel framing, where **CJ-Series** joists are utilized at column lines, the **CJ-Series** joists shall be field-bolted at the column. Before hoisting cables are released and before an employee is allowed on the **CJ-Series** joists the following conditions shall be met:
- 1) The seat at each end of the **CJ-Series** joists is attached in accordance with Section 5.7. Where a bolted seat connection is used for erection purposes, as a minimum, the bolts shall be snug tightened. The snug tight condition shall be defined as the tightness that exists where all plies of a joint are in firm contact. This shall be attained by a few impacts of an impact wrench or the full effort of an employee using an ordinary spud wrench.
  - 2) Where stabilizer plates are required the **CJ-Series** joists bottom chord shall engage the stabilizer plate.

During the construction period, the contractor shall provide means for the adequate distribution of loads so that the carrying capacity of any **CJ-Series** joist is not exceeded.

- b) Before an employee is allowed on the **CJ-Series** joist both ends of **CJ-Series** joist at columns shall be attached to its supports. For all other **CJ-Series** joists a minimum of one end shall be attached before the employee is allowed on the **CJ-Series** joist. The attachment shall be in accordance with Section 5.7.

Where a bolted seat connection is used for erection purposes, as a minimum, the bolts shall be snug tightened. The snug tight condition shall be defined as the tightness that exists where all plies of a joint are in firm contact. This shall be attained by a few impacts of an impact wrench or the full effort of an employee using an ordinary spud wrench.

- c) On **CJ-Series** joists that do not require Erection Bridging as determined by Section 5.5.2.1 or as shown on the joist placement plans, only one employee shall be allowed on the **CJ-Series** joist until all bridging is installed and anchored.
- d) Where the span of the **CJ-Series** joist is such that one row of Erection Bridging nearest the midspan is required in accordance with Section 5.5.2.1 or as indicated on the joist placement plans, the following shall apply:
- 1) Hoisting cables shall not be released until this bolted diagonal Erection Bridging row is installed and anchored, unless an alternate method of stabilizing the joist has been provided; and

- 2) No more than one employee shall be allowed on these spans until all other bridging is installed and anchored.
- e) Where the span of the **CJ-Series** steel joist exceeds 60'-0" (18228 mm and is less than or equal to 100'-0" (30175 mm), the following shall apply:
  - 1) All rows of bridging shall be bolted diagonal bridging; and
  - 2) Hoisting cables shall not be released until the two rows of bolted diagonal Erection Bridging nearest the third points of the **CJ-Series** joist are installed and anchored; and
  - 3) No more than two employees shall be allowed on these spans until all other bridging is installed and anchored.
- f) Where the span of the **CJ-Series** joist exceeds 100'-0" (30175 mm), the following shall apply:
  - 1) All rows of bridging shall be bolted diagonal bridging; and
  - 2) Hoisting cables shall not be released until all rows of bolted diagonal Erection Bridging is installed and anchored; and
  - 3) No more than two employees shall be allowed on these spans until all other bridging is installed and anchored.
- g) Where permanent bridging terminus points cannot be used during erection, additional temporary bridging terminus points shall be required to provide lateral stability.
- h) In the case of bottom chord bearing **CJ-Series** joists, the ends of the **CJ-Series** joist shall be restrained laterally per Section 5.5.6 before releasing the hoisting cables.
- i) After the **CJ-Series** joist is straightened and plumbed, and all bridging is completely installed and anchored, the ends of the **CJ-Series** joists shall be fully connected to the supports in accordance with Section 5.7.

## 6.2 LANDING AND PLACING LOADS

- a) Except as stated in Section 6.2(d), no "construction loads" shall be allowed on the **CJ-Series** joists until all bridging is installed and anchored, and all joist bearing ends are attached.

**User Note:** For the definition of "construction load" see the Federal Register, Department of Labor, Occupational Safety and Health Administration (2001), 29 CFR Part 1926 Safety Standards for Steel Erection; Final Rule, §1926.757 Open Web Steel Joists - January 18, 2001, Washington, D.C.

- b) During the construction period, loads placed on the **CJ-Series** joists shall be distributed so as not to exceed the capacity of the **CJ-Series** joists.
- c) The weight of a bundle of **CJ-Series** steel bridging shall not exceed a total of 1000 pounds (454 kilograms). The bundle of joist bridging shall be placed on a minimum of three **CJ-Series** joists that are secured at one end. The edge of the bridging bundle shall be positioned within 1 foot (0.30 m) of the secured end.
- d) No bundle of metal deck shall be placed on **CJ-Series** joists until all bridging has been installed and anchored and all joist bearing ends attached, unless the following conditions are met:
  - 1) The contractor has first determined from a "qualified person" and documented in a site-specific erection plan that the structure or portion of the structure is capable of supporting the load;
  - 2) The bundle of metal decking is placed on a minimum of three **CJ-Series** joists;
  - 3) The **CJ-Series** joists supporting the bundle of metal decking are attached at both ends;
  - 4) At least one row of bridging is installed and anchored;
  - 5) The total weight of the metal decking does not exceed 4000 pounds (1816 kilograms); and
  - 6) The edge of the bundle of metal decking is placed within 1 foot (0.30 meters) of the bearing surface of the **CJ-Series** joist end.

**User Note:** For the definition of “qualified person” see the Federal Register, Department of Labor, Occupational Safety and Health Administration (2001), 29 CFR Part 1926 Safety Standards for Steel Erection; Final Rule, §1926.757 Open Web Steel Joists - January 18, 2001, Washington, D.C.

- e) The edge of the construction load shall be placed within 1 foot (0.30 meters) of the bearing surface of the **CJ-Series** joist end.

### 6.3 FIELD WELDING

All field welding shall be performed in accordance with the structural drawings. Field welding shall not damage the **CJ-Series** joists.

On cold-formed steel members whose yield strength has been attained by cold working, and whose as-formed strength is used in the design, the total length of weld at any one point shall not exceed 50 percent of the overall developed width of the cold-formed section.

### 6.4 HANDLING

Particular attention shall be considered for the handling and erection of **CJ-Series** joists. Damage to the **CJ-Series** joists and accessories shall be avoided. Hoisting cables shall be attached at panel point locations and those locations shall be selected to minimize erection stresses.

Each **CJ-Series** steel joist shall be adequately braced laterally before any loads are applied. If lateral support is provided by bridging, the bridging lines as defined in Section 6.1(c), 6.1(d), 6.1(e), and 6.1(f) shall be anchored to prevent lateral movement.

### 6.5 FALL ARREST SYSTEMS

**CJ-Series** joists shall not be used as anchorage points for a fall arrest system unless written direction to do so is obtained from a “qualified person”.

**User Note:** For the definition of “qualified person” see the Federal Register, Department of Labor, Occupational Safety and Health Administration (2001), 29 CFR Part 1926 Safety Standards for Steel Erection; Final Rule, §1926.757 Open Web Steel Joists - January 18, 2001, Washington, D.C.

## SECTION 7 SHEAR CONNECTOR PLACEMENT AND WELDING

- a) Shear connectors required on each side of the point of maximum positive or negative bending moment, shall be distributed uniformly between that point and the adjacent points of zero moment, unless otherwise specified. However the number of shear connectors placed between any concentrated load and the nearest point of zero moment shall be sufficient to develop the maximum moment required at the concentrated load point.
- b) Studs shall be alternately placed on each chord angle section for double angle top chords. When constructability does not allow this to occur, stud placement shall be limited as follows:
- 1) No more than three studs shall be placed consecutively on any one chord angle, and
  - 2) No more than 60 percent of the total number of studs shall be placed on any one chord angle.

Studs shall have a minimum of ½ inch (13 mm) concrete cover over the head of each stud (see Section 4.5.4).

- c) The minimum center-to-center spacing of stud connectors shall be six stud diameters along the longitudinal axis of the supporting **CJ-Series** joist, except that within the ribs of formed metal decks oriented perpendicular to the **CJ-Series** joists, the minimum center-to-center spacing shall be four stud diameters in any direction.
- d) The distance measured along the longitudinal axis of the **CJ-Series** joist from the free edge of the concrete slab to the first stud shall not be less than the deck height plus four stud diameters.
- e) The spacing of stud shear connectors along the length of the supporting **CJ-Series** joist shall not exceed eight times the slab depth or 36 inches (914 mm).
- f) To resist uplift, the metal deck shall be anchored to all supporting members at a spacing not to exceed 18 inches (460 mm). Such anchorage shall be provided by stud connectors, a combination of stud connectors and arc spot (puddle) welds, or other devices.

## SECTION 8

### **SPECIAL CASES**

When a method of shear transfer is used other than headed shear studs for developing composite joist behavior, the strength of shear connectors and details of composite construction shall be established by a test program that has been submitted to and accepted by the SJI.